

mitsubishi

三菱工業用ミシン部品カタログ

Industrial Sewing Machine Parts Catalog

Model PLK-E4519
PLK-E6019

目次	CONTENTS	Page
A 本体構成	Construction	1
B 本体関係(1)	Arm bed & it's accessories (1).....	2
C 本体関係(2)	Arm bed & it's accessories (2).....	4
D 本体関係(3)	Arm bed & it's accessories (3).....	6
E 本体関係(4)	Arm bed & it's accessories (4).....	8
F 縫い機構(1)	Sewing mechanism (1).....	10
G 縫い機構(2)	Sewing mechanism (2).....	12
H 中押え機構	Presser bar lifting mechanism	14
J 糸切り機構	Thread trimming mechanism	16
K X-Yテーブル機構(1)	X-Y table mechanism (1).....	18
L X-Yテーブル機構(2)	X-Y table mechanism (2).....	20
M 外押え機構	Work holder mechanism	22
N ワイパー機構	Wiper mechanism	24
P 給油機構	Oil lubrication mechanism	26
Q 配線・配管関係	Cable component & Pneumatic control unit	28
R テーブル関係	Table & Stand	30
S 付属品	Accessories	32
T オプションパーツ	Option parts	34
索引	Index	36

部品コードの採番形式

MITSUBISHI SPARE PARTS No. Designation system

1. 部品コードについて CONCERNING PARTS CODE.

部品をご注文される場合は、部品コードをお知らせください。

Please inform the part number, when these parts are ordered.

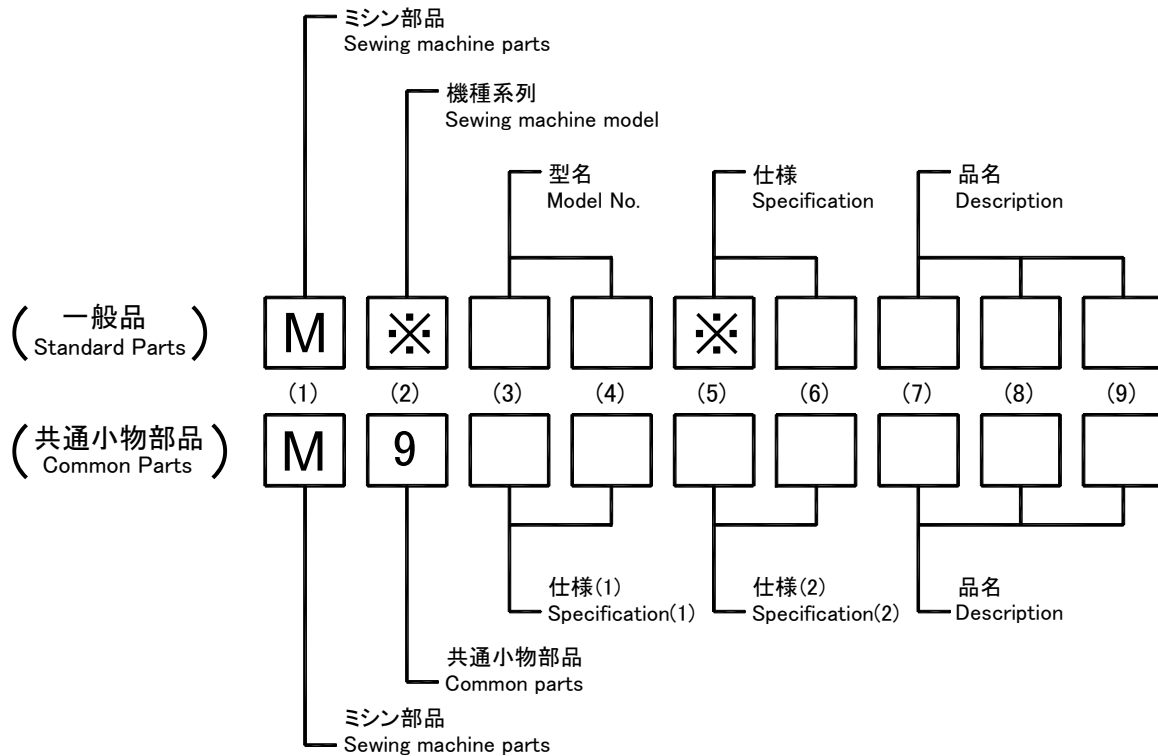

[例] Example

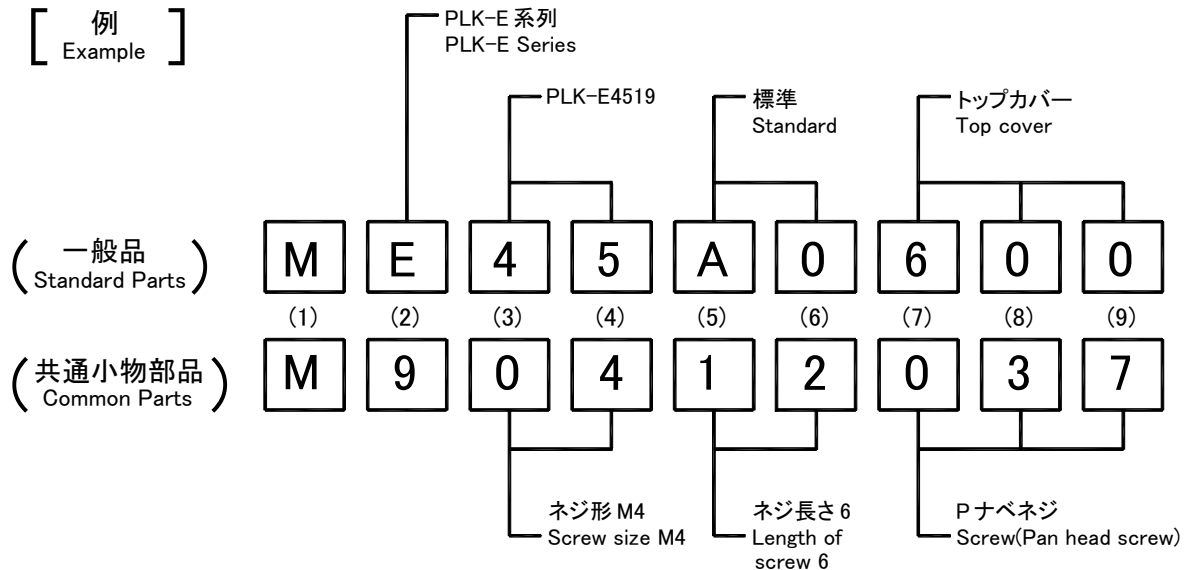

2. 変更マークについて CONCERNING MODIFICATION MARK.

変更マーク欄に*記号のある部品は、形状、寸法などの変更履歴がありますので、ご注文の際にはご使用の製品の製造番号と合わせてご覧ください。

The parts marked with * in the modification column has been changed the shape or size etc. So when these modified parts are ordered please inform the serial number of the sewing machine.

注: 一般品についての機種型名は、その部品が最初に使用された機種型名を示します。

従って長期にわたる場合は、機種の改廃が行われるため、当初の機種以外の機種で使用されている場合があります。

Sewing machine Models, of Standard Parts are Indicated model of these parts are registered firstly. Parts are used for not only the indicated model, but also another models, in reason of New development, improvement after.

A 全体構成
CONSTRUCTION

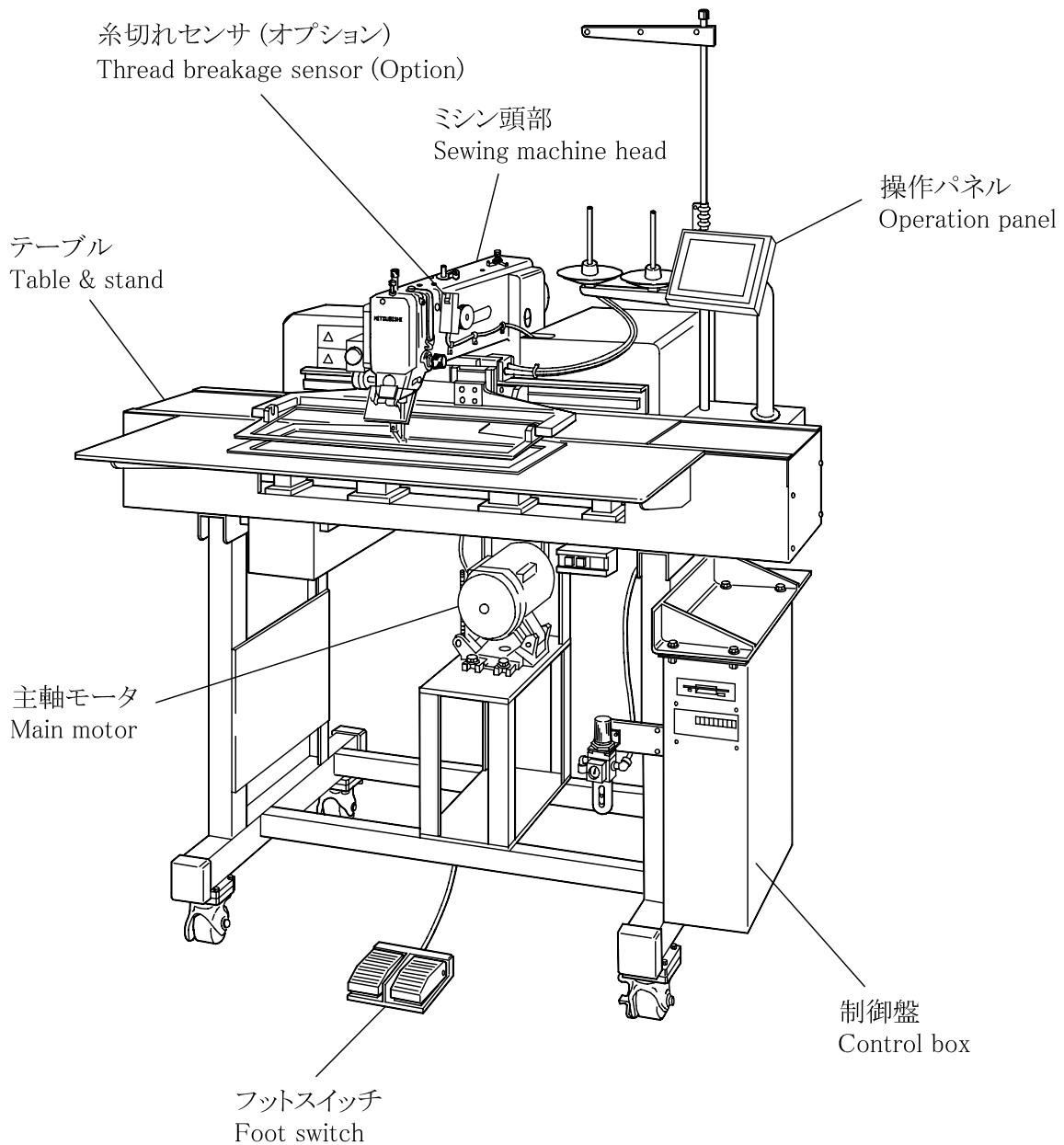

注1：モータ部分は三菱リミサーボX部品カタログを参照ください。

注2：Fig.No.の採番していない部品は単体で支給することは出来ません。Setにて支給いたします。

Remarks 1) Concerning about the motor parts please refer to the parts catalog of MITSUBISHI LIMISERVO X.

Remarks 2) The parts which Fig.No. are not marked are not available individually. It can be supplied with the whole component.

B 本体関係(1)
ARM BED & IT'S ACCESSORIES(1)

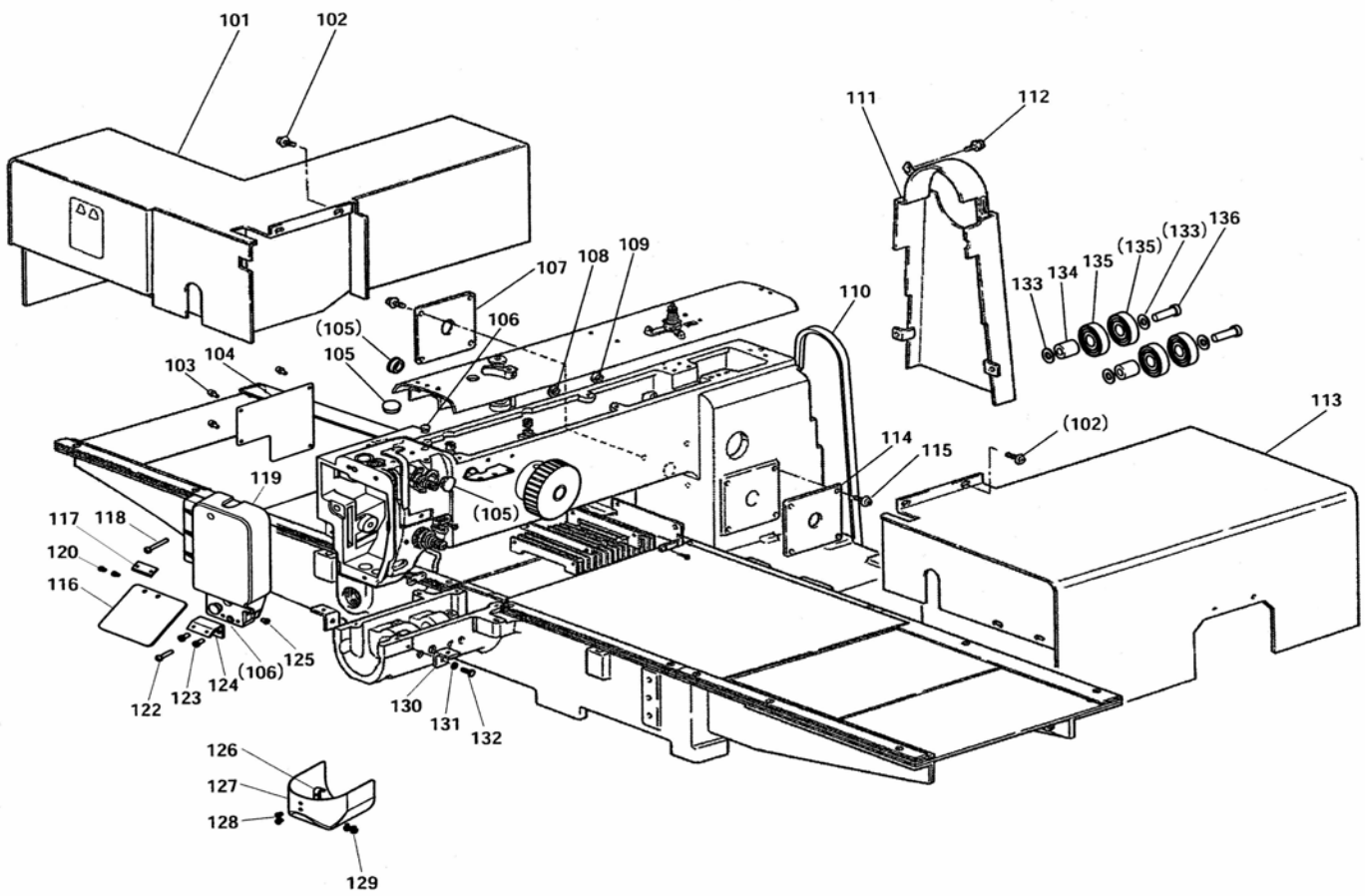

[B]本体関係(1)
ARM BED & IT'S ACCESSORIES (1)

Fig no.	変更 Mod.	部品コード Parts no.	品名	Description	数量	
					Amt. 4519	Req. 6019
B 101		MB45A0849	モータカバー	Motor cover	1	1
B 102		M91071004	SW-MWプラマイナネジ M4X8	Screw M4X8	11	11
B 103		M91054004	SW-PWプラマイナネジ M4X8	Screw M4X8	4	4
B 104		ME10A0742	フタ	Cover	1	1
B 105		M91910080	ゴムセン φ19	Rubber plug φ19	3	3
B 106		M91182080	ゴムセン φ11.8	Rubber plug φ11.8	2	2
B 107		MA45A0339	カバー	Cover	1	1
B 108		M90883080	ゴムセン φ8.8	Rubber plug φ8.8	1	1
B 109		M91304080	ゴムセン φ13	Rubber plug φ13	1	1
B 110		MA20A0777	Vベルト M52	V belt M52	1	1
B 111		MA45A0776	ベルトカバー	Belt cover	1	1
B 112		M91300004	SW-MWプラマイナネジ M5X8	Screw M5X8	3	3
B 113		MB45A1849	モータカバー	Motor cover	1	1
B 114		MA45A3339	カバー	Cover	1	1
B 115		M95005017	セフティソケット M5X10	Bolt M5X10	8	8
B 116		MS01A0160	アイガード	Eye guard	1	1
B 117		MS01A0477	ストッパ	Adapter	1	1
B 118		M90447037	プラマイナネジ M4X25	Screw M4X25	1	1
B 119		ME10E1830	メンタ	Face cover	1	1
B 120		M90806002	ヒラネジ 1/8(44)X6	Screw 1/8(44)X6	2	2
B 122		M91079004	プラマイナネジ M4X16	Screw M4X16	1	1
B 123		M91110002	ヒラネジ 11/64(40)X8	Screw 11/64(40)X8	2	2
B 124		MB60A0601	アイガードトリツケイタ	Eye guard bracket	1	1
B 125		M90909003	マルヒラネジ 9/64(40)X6	Screw 9/64(40)X6	1	1
B 126		MS01A0361	カケカネ	Latch	1	1
B 127		MB60E6339	シリンダーカバー	Cylinder cover	1	1
B 128		M90906003	マルヒラネジ 9/64(40)X3.2	Screw 9/64(40)X3.2	2	2
B 129		M90859004	SW-PWプラマイナネジ M3X6	Screw M3X6	2	2
B 130		MB62A4601	トリツケイタ	Adapter	2	2
B 131		M90421050	ワッシャ 4	Washer 4	2	2
B 132		M94001017	セフティソケット M4X10	Bolt M4X10	2	2
B 133		M90823050	ワッシャ 8	Washer 8	4	4
B 134		MB60A0750	ブッシュ	Bushing	2	2
B 135		MS10A1456	ジクウケ 6202ZZ	Bearing 6202ZZ	4	4
B 136		M91803022	ロックアナツキボルト M8X40	Bolt M8X40	2	2

C 本体関係(2)
ARM BED & IT'S ACCESSORIES(2)

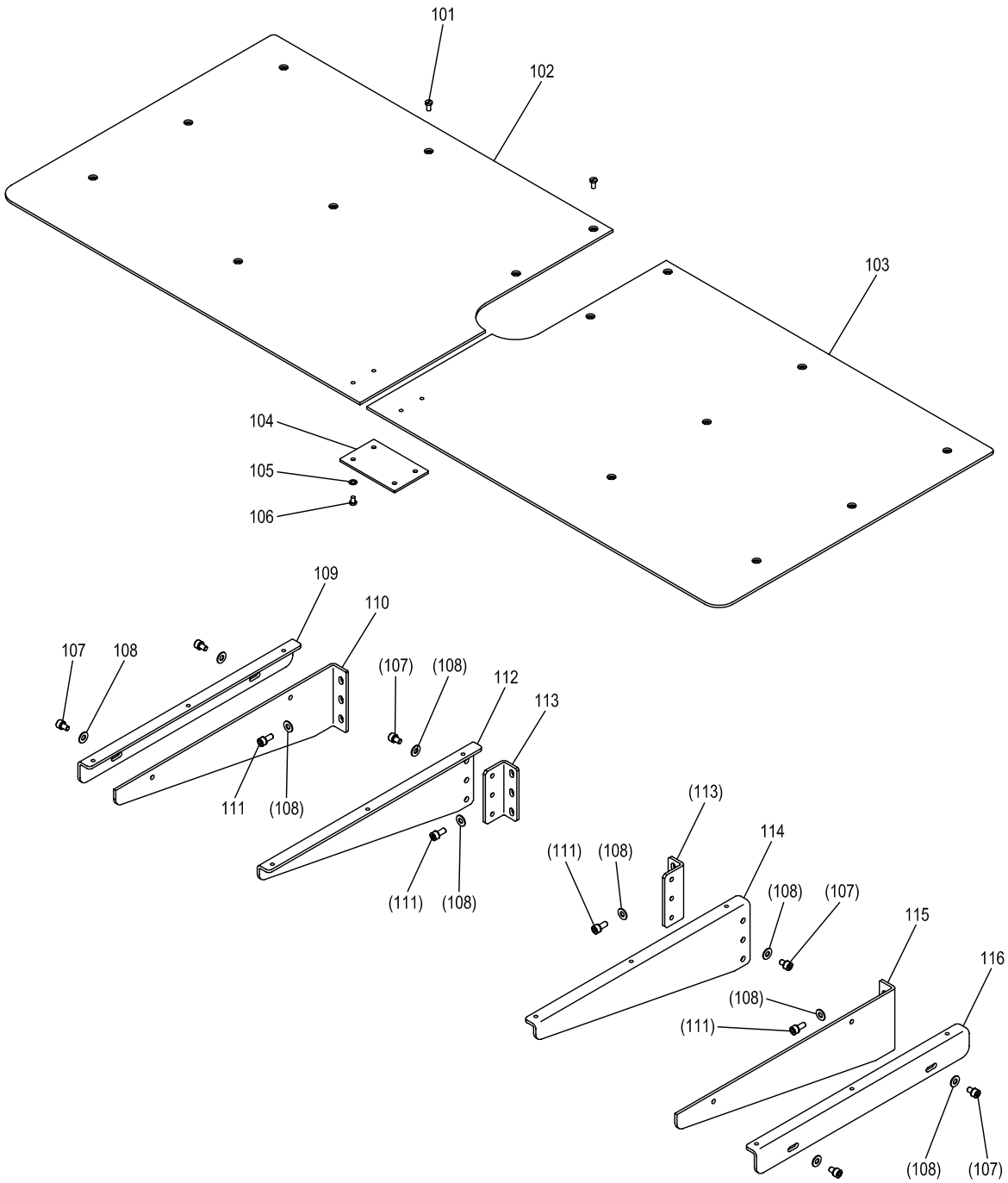

[C]本体関係(2)

ARM BED & IT'S ACCESSORIES (2)

Fig no.	変更 Mod.	部品コード Parts no.	品 名	Description	数量	
					Amt. 4519	Req. 6019
C 101		M90990002	ヒラネジ M4X8	Screw M4X8	16	16
C 102		MA45A0473	スベリイタ (ヒタリ)	Slide plate (left)	1	*
C 102		MA61A0473	スベリイタ (ヒタリ)	Slide plate (left)	*	1
C 103		MA45A0474	スベリイタ (ミキ)	Slide plate (right)	1	*
C 103		MA61A0474	スベリイタ (ミキ)	Slide plate (right)	*	1
C 104		MA35A0601	トリツケイタ	Adapter	1	1
C 105		M90422050	サガネ 4	Washer 4	4	4
C 106		M91011004	ナネネジ M4X6	Screw M4X6	4	4
C 107		M91511056	セフティソケット M5X8	Bolt M5X8	10	10
C 108		M90511050	サガネ 5	Washer 5	22	22
C 109		MA45A2426	ササエカナク (ヒタリ)	Bracket (left)	1	1
C 110		MA45A1361	Lカクカナク (ヒタリ)	L-type bracket (left)	1	*
C 110		MA61A1361	Lカクカナク (ヒタリ)	L-type bracket (left)	*	1
C 111		M95002017	セフティソケット M5X12	Bolt M5X12	12	12
C 112		MB45B1426	ササエカナク (ヒタリ)	Bracket (left)	1	1
C 113		MA20A0361	Lカクカナク	L-type bracket	2	2
C 114		MB45A1426	ササエカナク (ミキ)	Bracket (right)	1	1
C 115		MA45A0361	Lカクカナク (ミキ)	L-type bracket (right)	1	*
C 115		MA61A0361	Lカクカナク (ミキ)	L-type bracket (right)	*	1
C 116		MB45A0426	ササエカナク (ミキ)	Bracket (right)	1	1

D 本体関係(3)
 ARM BED & IT'S ACCESSORIES(3)

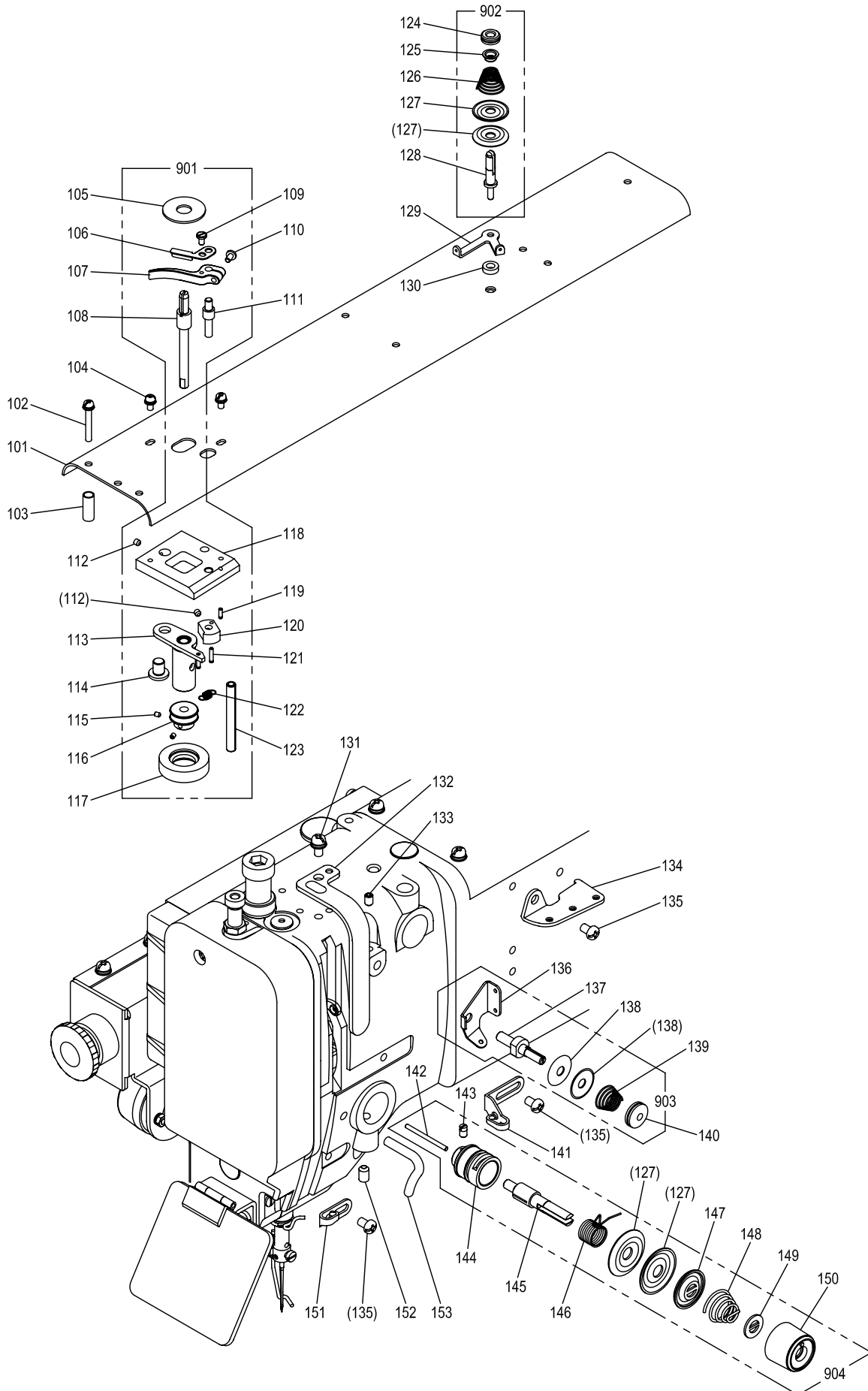

[D]本体関係(3)
ARM BED & IT'S ACCESSORIES(3)

Fig no.	変更 Mod.	部品コード Parts no.	品名	Description	数量	
					Amt. 4519	Req. 6019
D 101	ME45A0600		トップカバー	Top cover	1	1
D 102	M91276004		SW-PWプラマイナネジ M4X30	Screw M4X30	5	5
D 103	MB62A0352		スペーサ 1382312-60200	Spacer	5	5
D 104	M91013004		SW-MWプラマイナネジ M4X10	Screw M4X10	2	2
D 105	MA20A0476		スペーサー	Spacer	1	1
D 106	ME25A0551		チョウセツイタ	Adjuster plate	1	1
D 107	ME25A0950		レバー	Lever	1	1
D 108	MA04A1530		ダンツキジク D	Driven shaft	1	1
D 109	M90920002		ヒラネジ 9/64(40)X6.5	Screw 9/64(40)X6.5	1	1
D 110	M90939002		ヒラネジ 9/64(40)X11	Screw 9/64(40)X11	1	1
D 111	MA04A2530		ダンツキジク	Shaft	1	1
D 112	M91055020		ロッカクアナツキトメネジ M4X4	Screw M4X4	2	2
D 113	MB60E2750		ブッシュクミタテ	Bushing	1	1
D 114	M99006063		ピン	Pin	1	1
D 115	M91057020		ロッカクアナツキトメネジ M3X4	Screw M3X4	2	2
D 116	MA20A0194		イマキグルマ	Wheel	1	1
D 117	MS03A0417		ゴムワ	Tire	1	1
D 118	MB60A1601		トリツケイタ	Bracket	1	1
D 119	M91004067		ミゾツキピン BXガタ φ2.5X8	Pin φ2.5X8	1	1
D 120	MS14A0350		カム	Cam	1	1
D 121	M91005067		ミゾツキピン BXガタ φ2.5X12	Pin φ2.5X12	2	2
D 122	MS14A0572		ツルマキハネ	Spring	1	1
D 123	M90601064		スプリングピン φ6X56	Pin φ6X56	1	1
D 124	M91602046		ツマミナット	Thumb nut	1	1
D 125	MM11A0702		バネアンナイ	Spring guide	1	1
D 126	MM11A0245		エンスイハネ	Thread tension spring	1	1
D 127	MF10A0555		チョウシサラ	Thread tension discs	4	4
D 128	MS14A0553		チョウシホウ	Thread tension stud	1	1
D 129	MS14A1180		トアンナイ	Thread guide	1	1
D 130	MG75A1476		スペーサ	Spacer	1	1
D 131	M91054004		SW-PWプラマイナネジ M4X8	Screw M4X8	1	1
D 132	MA20A0584		テンピンカバー	Thread take-up lever guard	1	1
D 133	M91053020		ロッカクアナツキトメネジ M4X6	Screw M4X6	1	1
D 134	MF36A1180		トアンナイ	Thread guide	1	1
D 135	M91011004		プラマイナネジ M4X6	Screw M4X6	3	3
D 136	MF00A0181		トアンナイ	Thread guide	1	1
D 137	MF00A0553		チョウシホウ	Thread tension stud	1	1
D 138	MF10A1555		チョウシサラ	Thread tension discs	2	2
D 139	MF36A0245		エンスイハネ	Thread tension spring	1	1
D 140	M91101046		ツマミナット	Thumb nut	1	1
D 141	MG43A0181		トアンナイ	Thread guide	1	1
D 142	M90204060		ピン	Pin	1	1
D 143	M90901002		ヒラネジ 9/64(40)X4	Screw 9/64(40)X4	1	1
D 144	MF10A0709		ブッシュ	Regulator casing	1	1
D 145	MF10A0553		チョウシホウ	Thread tension stud	1	1
D 146	MF10A0187		イトリハネ	Thread take-up spring	1	1
D 147	MM11A0556		チョウシサラオサエ	Disc retaining plate	1	1
D 148	MN52A1245		エンスイハネ	Thread tension spring	1	1
D 149	MT60A0802		マワリトメ	Thumb nut revolution stopper	1	1
D 150	M91610046		ツマミナット	Thumb nut	1	1
D 151	MF10A0181		トアンナイ	Thread guide	1	1
D 152	M95004020		ロッカクアナツキトメネジ M5X8	Screw M5X8	1	1
D 153	MF70A1180		トアンナイ	Thread guide	1	1
D 901	ME25E0190		イマキソウチクミタテ	Bobbin winder	1	1
D 902	MS14E0180		チョウセツキクミタテ	Thread tension Regulator assy	1	1
D 903	MF00E0550		チョウセツキクミタテ	Thread tension Regulator assy	1	1
D 904	MA16E0210		チョウセツキクミタテ	Thread tension Regulator assy	1	1

From the library of: Diamond Needle Corp

E 本体関係(4)
ARM BED & IT'S ACCESSORIES(4)

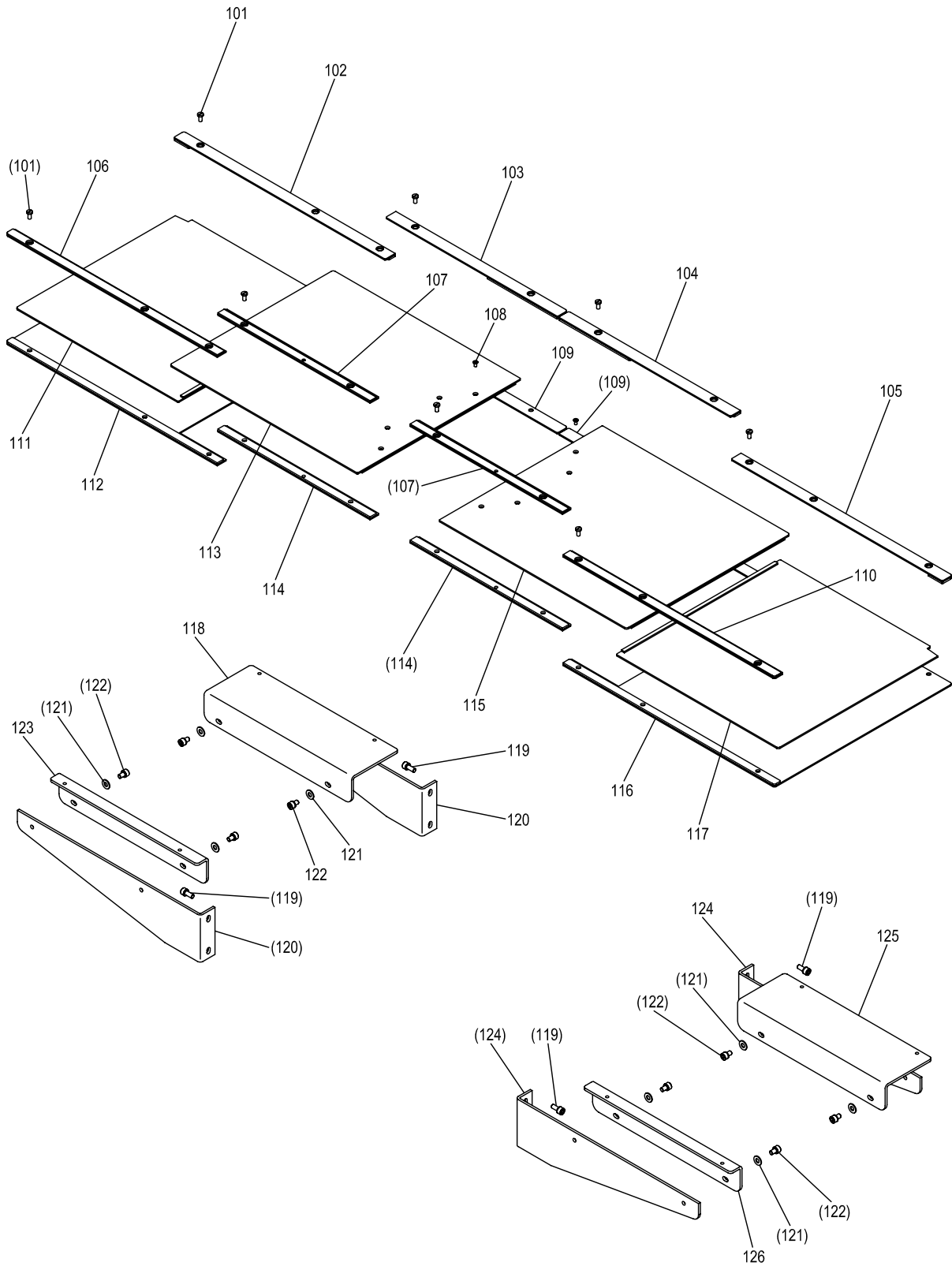

[E] 本体関係(4)

ARM BED & IT'S ACCESSORIES(4)

Fig no.	変更 Mod.	部品コード Parts no.	品 名	Description	数量	
					Amt. Req. 4519	6019
E 101		M90990002	ヒラネジ M4X8	Screw M4X8	20	20
E 102		MB45B2359	カバーガイド (ヒタリ)	Cover guide (left)	1	*
E 102		MB69B0359	カバーガイド (ヒタリ)	Cover guide (left)	*	1
E 103		MB45B1359	カバーガイド (ヒタリ)	Cover guide (left)	1	*
E 103		ME69B0359	カバーガイド (ヒタリ)	Cover guide (left)	*	1
E 104		MB45A1359	カバーガイド (ミキ)	Cover guide (right)	1	*
E 104		ME69A0359	カバーガイド (ミキ)	Cover guide (right)	*	1
E 105		MB45A2359	カバーガイド (ミキ)	Cover guide (right)	1	*
E 105		MB69A0359	カバーガイド (ミキ)	Cover guide (right)	*	1
E 106		MA45A6359	カバーガイド (ヒタリ)	Cover guide (left)	1	*
E 106		MA61A6359	カバーガイド (ヒタリ)	Cover guide (left)	*	1
E 107		MA45A0359	カバーガイド	Cover guide	2	2
E 108		M90352037	Pサラネジ M3X6	Screw M3X6	8	8
E 109		MB45A0476	スペーサ	Spacer	2	2
E 110		MA45A3359	カバーガイド (ミキ)	Cover guide (right)	1	*
E 110		MA61A3359	カバーガイド (ミキ)	Cover guide (right)	*	1
E 111		MB45B1339	Xイトウカバー (ミキ)	X-Movable cover (right)	1	*
E 111		MB69B1339	Xイトウカバー (ミキ)	X-Movable cover (right)	*	1
E 112		MB45B0339	X-Yカバー (ヒタリ)	Cover (left)	1	*
E 112		MB69B0339	X-Yカバー (ヒタリ)	Cover (left)	*	1
E 113		MA45A4339	Xカバーイタ (ヒタリ)	X-Cover plate (left)	1	*
E 113		MA61A4339	Xカバーイタ (ヒタリ)	X-Cover plate (left)	*	1
E 114		MB45A1476	スペーサ	Spacer	2	2
E 115		MA45A5339	Xカバーイタ (ミキ)	X-Cover plate (right)	1	*
E 115		MA61A5339	Xカバーイタ (ミキ)	X-Cover plate (right)	*	1
E 116		MB45A0339	X-Yカバー (ミキ)	Cover (right)	1	*
E 116		MB69A0339	X-Yカバー (ミキ)	Cover (right)	*	1
E 117		MB45A1339	Xイトウカバー (ヒタリ)	X-Movable cover (left)	1	*
E 117		MB69A1339	Xイトウカバー (ヒタリ)	X-Movable cover (left)	*	1
E 118		MB45B2426	ササエカナク (ヒタリ)	Bracket (left)	1	*
E 118		MB69B0426	ササエカナク (ヒタリ)	Bracket (left)	*	1
E 119		M95002017	セフティソケット M5X12	Bolt M5X12	8	8
E 120		MA45A3361	Lカタカナク (ヒタリ)	L-Bracket (left)	2	*
E 120		MA61A3361	Lカタカナク (ヒタリ)	L-Bracket (left)	*	2
E 121		M90511050	ザガネ 5	Washer 5	8	8
E 122		M91511056	セフティソケット M5X8	Bolt M5X8	8	8
E 123		MB45B3426	ササエカナク (ヒタリ)	Bracket (left)	1	*
E 123		MB69B1426	ササエカナク (ヒタリ)	Bracket (left)	*	1
E 124		MA45A2361	Lカタカナク (ミキ)	L-Bracket (right)	2	*
E 124		MA61A2361	Lカタカナク (ミキ)	L-Bracket (right)	*	2
E 125		MB45A2426	ササエカナク (ミキ)	Bracket (right)	1	*
E 125		MB69A0426	ササエカナク (ミキ)	Bracket (right)	*	1
E 126		MB45A3426	ササエカナク (ミキ)	Bracket (right)	1	*
E 126		MB69A1426	ササエカナク (ミキ)	Bracket (right)	*	1

From the library of: Diamond Needle Corp

F 縫い機構(1)
SEWING MECHANISM(1)

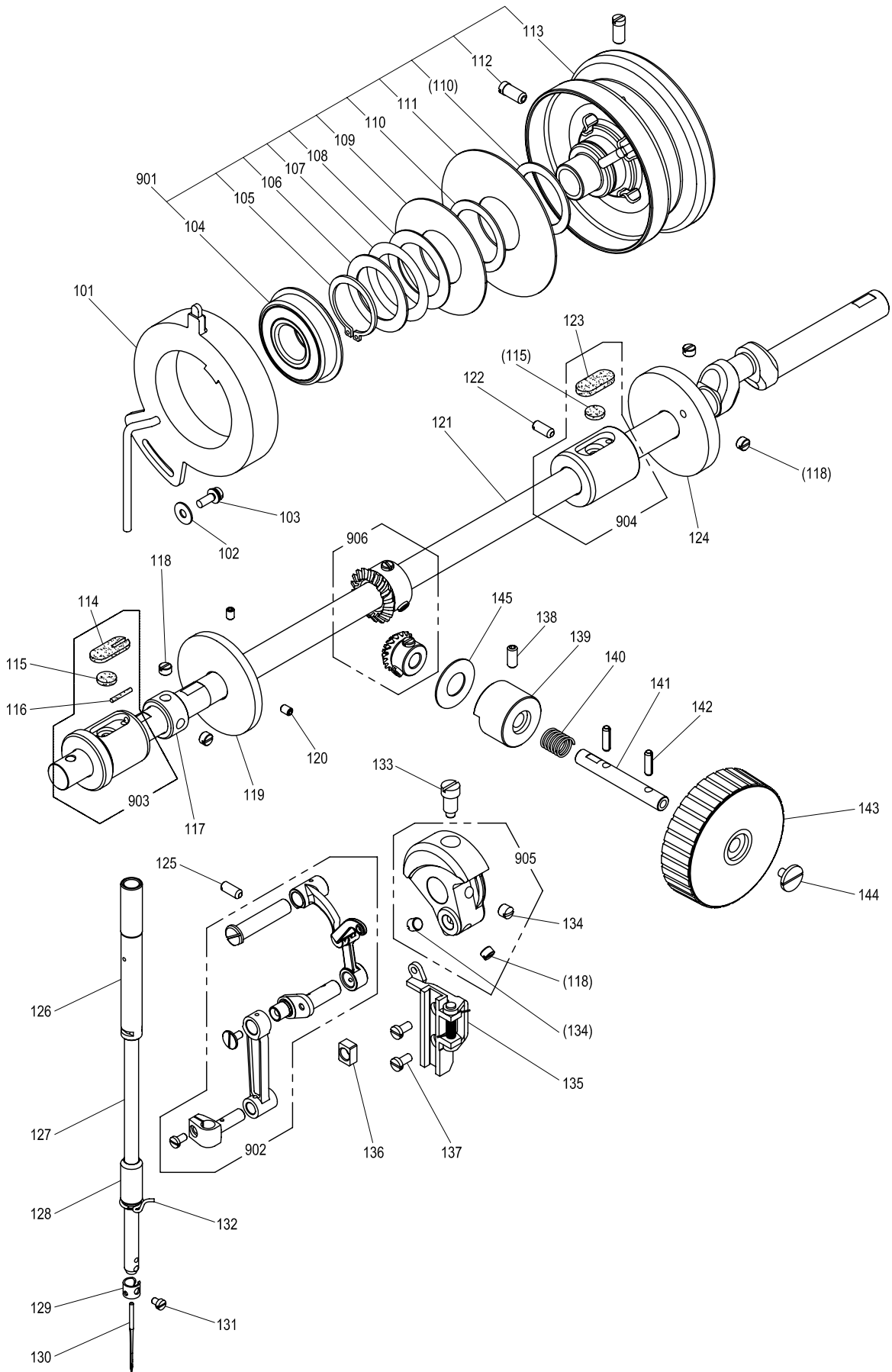

[F]縫い機構(1)
SEWING MECHANISM (1)

Fig no.	変更 Mod.	部品コード Parts no.	品名	Description	数量	
					Amt. 4519	Req. 6019
F 101	A	ME20A0406	ウワシクケンシュツキ	Detector	1	1
F 102		M90421050	ザガネ 4	Washer 4	1	1
F 103		M91059004	SW-PWプラマイナベネジ M4X12	Screw M4X12	1	1
F 104		MN10A1456	ボールベアリング	Ball bearing	1	1
F 105		M90330065	Cガ外ワ 30	C-type retaining ring 30	1	1
F 106		M93001050	ザガネ	Washer	1	1
F 107		MF01A0259	ナミザガネ	Wave washer	1	1
F 108		MF01A1476	スペーサー B	Spacer B	1	1
F 109		MN72A1694	ハンシャパン F20 (ウワイチ)	Command disk F20 (up)	1	1
F 110		MF01A0476	スペーサー A	Spacer A	2	2
F 111		MB60A0694	ハンシャパン K10 (シタイチ)	Command disk K10 (down)	1	1
F 112		M91520002	ヒラネジ 15/64(28)X12	Screw 15/64(28)X12	2	2
F 113		MB60E0682	プーリー	Pulley	1	1
F 114		MG50A0740	フェルト	Felt	1	1
F 115		MS10A1740	フェルト	Felt	2	2
F 116		MV88A0740	フェルト	Felt	1	1
F 117		MF70A0352	カラー	Collar	1	1
F 118		M91602001	トメネジ 1/4(40)X4	Screw 1/4(40)X4	5	5
F 119		MS14A0682	イトマキプーリー	Pulley	1	1
F 120		M91053020	ロッカクアナツキトメネジ M4X6	Screw M4X6	2	2
F 121		ME45A0230	ウワシク	Drive shaft	1	1
F 122	A	M95003001	トメネジ M5X12	Screw M5X12	1	1
F 123		MF60A2740	フェルト	Felt	1	1
F 124		MS01A0350	イトキリカム	Thread trimmer cam	1	1
F 125		M91221001	トメネジ M5X12	Screw M5X12	1	1
F 126		MS01A0663	ハリホウメタル (ウエ)	Needle bar bushing (upper)	1	1
F 127		MS01A0660	ハリホウ	Needle bar	1	1
F 128		MG30A0664	ハリホウメタル (シタ)	Needle bar bushing (lower)	1	1
F 129		MF21D0181	イトアンナイ	Thread guide	1	1
F 130		MS02A0128	ミシンハリ DPX17#18	Needle DPX17#18	1	1
F 131		M90815002	ヒラネジ 1/8(44)X4.5	Screw 1/8(44)X4.5	1	1
F 132		MF01A0181	イトアンナイ	Thread guide	1	1
F 133		M91802006	ヒラネジボウサキ 9/32(28)	Set screw 9/32(28)	1	1
F 134		M91606001	トメネジ 1/4(40)X6	Screw 1/4(40)X6	2	2
F 135		MS03E0662	ハリクガイドクミタテ	Guide assy	1	1
F 136		MF10A0325	カクコマ	Square block	1	1
F 137		M90990002	ヒラネジ M4X8	Screw M4X8	2	2
F 138		M95006020	ロッカクアナツキトメネジ M5X12	Screw M5X12	1	1
F 139		ME25A0833	メタル	Bushing	1	1
F 140		MA35A2572	ツルマキハネ	Spring	1	1
F 141		ME25A0454	ジク	Shaft	1	1
F 142		M90406064	スプリングピン φ4X14	Pin φ4X14	2	2
F 143		ME25A0682	テマワシプーリー	Hand pulley	1	1
F 144		M91119002	ヒラネジ	Screw M4X8	1	1
F 145	A	ME25A0416	カンショウゴム	Rubber plate	1	1
F 901		MB60E1682	プーリークミタテ	Pulley assy	1	1
F 902		MS01E0580	テンピンハリククミタテ	Thread take-up lever assy	1	1
F 903		MS10A0232	ウワシクメタル(ヒタリ)クミ	Drive shaft bushing L assy	1	1
F 904		MB60E0234	ウワシクメタル(ナカ)クミ	Drive shaft bushing C assy	1	1
F 905		MS01A0383	クランククミ	Crank assy	1	1
F 906		ME25E0331	カサハグルマクミ	Bevel gear assy	1	1

G 縫い機構(2)
SEWING MECHANISM(2)

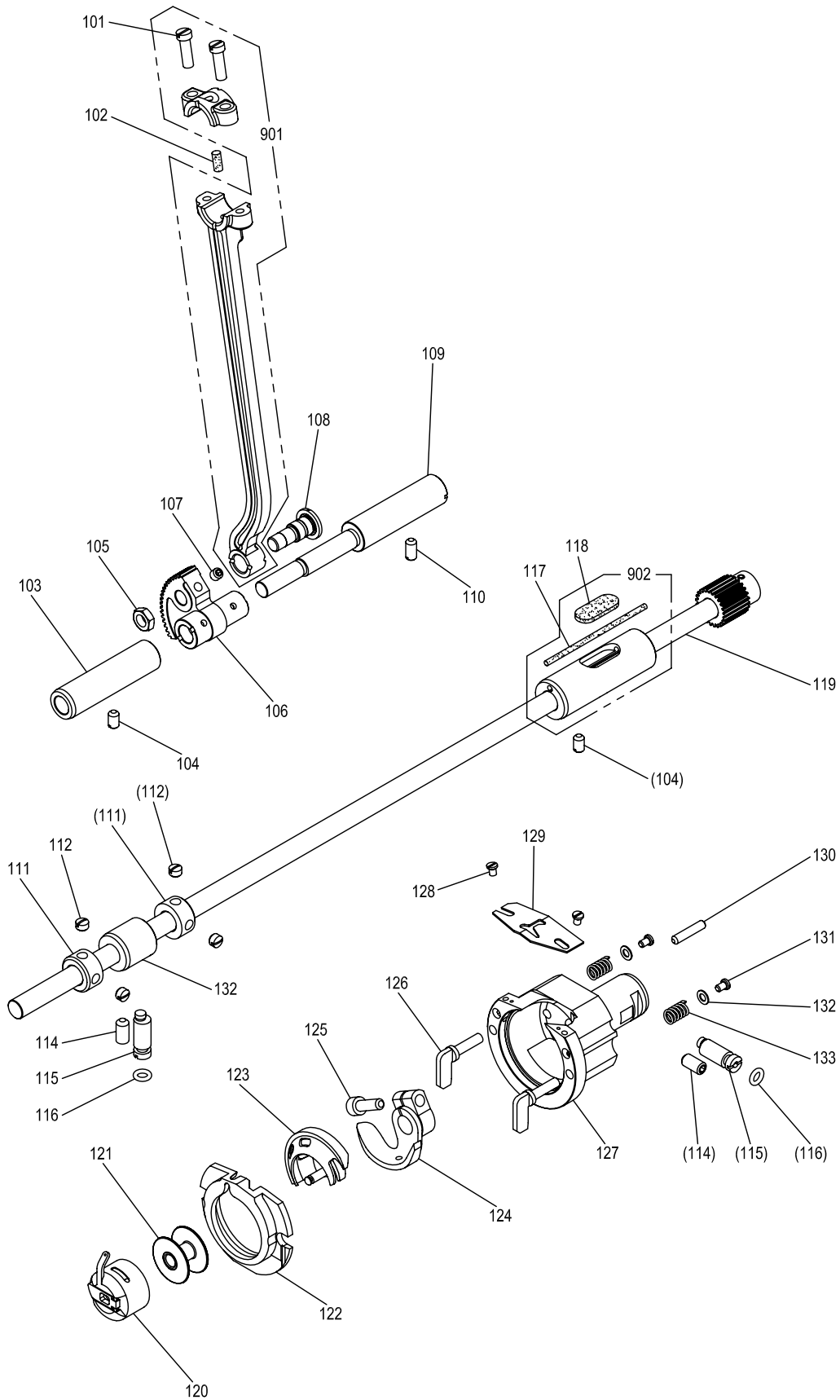

[G]縫い機構(2)

SEWING MECHANISM (2)

Fig no.	変更 Mod.	部品コード Parts no.	品 名	Description	数量	
					Amt. 4519	Req. 6019
G 101		M91203002	ヒラネジ 3/16(28)X15	Screw 3/16(28)X15	2	2
G 102		MB60A0740	フェルト	Felt	1	1
G 103		MS01A0833	メタル	Bushing	1	1
G 104		M91223001	トメネジ M5X10	Screw M5X10	2	2
G 105		M91802045	ナット 9/32(28)	Nut 9/32(28)	1	1
G 106		MS01A0508	セクタハグルマ	Sector gear	1	1
G 107		M95004021	ロッカアナツキトメネジ M5X5	Screw M5X5	1	1
G 108		M98003015	ヒラネジダツキ 9/32(28)	Screw 9/32(28)	1	1
G 109		MS01A0891	ヨウトウシク	Rock shaft	1	1
G 110		M91221001	トメネジ M5X12	Screw M5X12	1	1
G 111		MM11A0352	カラー	Collar	2	2
G 112		M91503001	トメネジ 15/64(28)X4.5	Screw 15/64(28)X4.5	4	4
G 113		MB62A0453	シタジクメタル(ナカ)	Hook shaft bushing (C)	1	1
G 114		M96002020	ロッカアナツキトメネジ M6X12	Screw M6X12	2	2
G 115		MS01A0761	ヘンシク	Eccentric shaft	2	2
G 116		M90500085	O リング	O-ring	2	2
G 117		ME10A0148	ヒモ	Oil braid	1	1
G 118		MA20A0740	フェルト	Felt	2	2
G 119		MA20E0450	シタジク クミ	Hook shaft assy	1	1
G 120		MS17A0125	ホビンケース SC-181	Bobbin case	1	1
G 121		MA10A0123	ホビン	Bobbin	1	1
G 122		MS08A0616	ナカガマオサエ	Hook retainer	1	1
G 123		MA10A0120	ナカガマ	Inner hook	1	1
G 124		MS01A0611	ドライバ	Hook driver	1	1
G 125		M95001021	ロッカアナツキホルト M5X16	Bolt M5X16	1	1
G 126		MS09A0950	カマオサエツマミ	Hook clamp	2	2
G 127		MS01A0121	ソトガマ	Outer hook	1	1
G 128		M90853002	ヒラネジ 1/8(40)X4	Screw 1/8(40)X4	2	2
G 129		MS01A0329	カマイトアンナイ	Thread guide	1	1
G 130		M90001060	ヘイコウピン M6-4X18	Pin M6-4X18	1	1
G 131		M90802003	マルヒラネジ 1/8(44)X4.5	Screw 1/8(44)X4.5	2	2
G 132		M93006050	ザガネ	Washer	2	2
G 133		MS01A0572	ツルマキハネ	Spring	2	2
G 901		MB60E1956	レンセツカン クミ	Connecting rod assy	1	1
G 902		ME10E0452	シタジクメタル(ミキ)クミ	Hook shaft bushing (R) assy	1	1

H 中押え機構
PRESSER BAR LIFTING MECHANISM

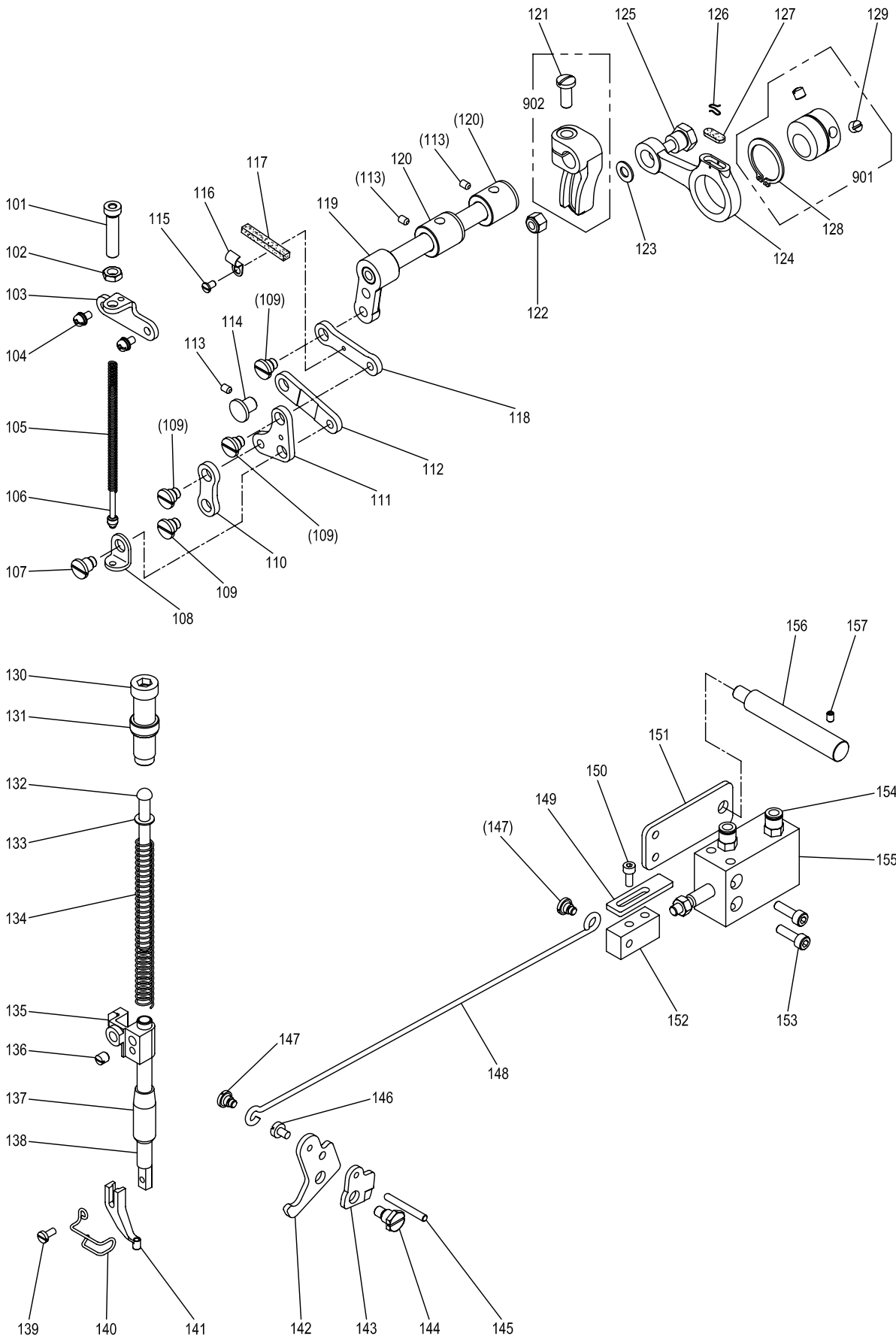

[H] 中押え機構

PRESSER BAR LIFTING MECHANISM

Fig no.	変更 Mod.	部品コード Parts no.	品名	Description	数量	
					4519	6019
H 101		M91801035	ツマミネジ 9/32(28)X35	Thumb screw 9/32(28)X35	1	1
H 102		M91802045	ナット 9/32(28)	Nut 9/32(28)	1	1
H 103		ME10A0261	オサエジョウセツダイ	Bracket	1	1
H 104		M91056004	SW-PWフライマインネジ M4X10	Screw M4X10	2	2
H 105		ME10A0572	ツルマキハネ	Spring	1	1
H 106		MS03A6154	アンナイガネ	Spring guide bar	1	1
H 107		M91689015	ヒラネジダンツキ 1/4(40)	Screw 1/4(40)	1	1
H 108		MG30B0226	オサエイタササエ	Supporter	1	1
H 109		M91688015	ヒラネジダンツキ 1/4(40)	Screw 1/4(40)	4	4
H 110		ME10A6910	リンク	Link	1	1
H 111		ME10A0763	ベルクランク	Bell crank	1	1
H 112		ME10A7910	リンク	Link	1	1
H 113		M91058020	ロッカクアナツキトメネジ M4X10	Screw M4X10	3	3
H 114		M99006063	ツパツキシク	Pin	1	1
H 115		M90909003	マルヒラネジ 9/64(40)X6	Screw 9/64(40)X6	1	1
H 116		MN70A1780	ホルダ	Holder	1	1
H 117		MG30A0740	フェルト	Felt	1	1
H 118		ME10A1956	レンセツカン	Link	1	1
H 119		MS02E0460	ウデクミタテ	Arm shaft assy	1	1
H 120		MG30A0833	メタル	Bushing	2	2
H 121		M91603003	マルヒラネジ 1/4(40)X16	Screw 1/4(40)X16	1	1
H 122		M91572045	U ナット 6X0.75	U-nut 6X0.75	1	1
H 123		M90631050	ザガネ 6	Washer 6	1	1
H 124		ME10A0956	レンセツカン	Crank rod	1	1
H 125		M91551015	ホルトダンツキ M6	Bolt M6	1	1
H 126		MF60A0700	センサイクハネ	Holder	1	1
H 127		MG30B0740	フェルト	Felt	1	1
H 128		M90325065	Cガ外メワ 25	C-type retaining ring 25	1	1
H 129		M91606001	トメネジ 1/4(40)X6	Screw 1/4(40)X6	2	2
H 130		M93220035	ツマミネジ 1/2(28)X43	Thumb screw 1/2(28)X43	1	1
H 131		M93202047	ナット 1/2(28)	Nut 1/2(28)	1	1
H 132		MS03A0703	アンナイボウ	Presser bar guide	1	1
H 133		M90632050	コザガネ 6	Washer 6	1	1
H 134		MS03A1572	ツルマキハネ	Spring	1	1
H 135		MG75A0265	オサエボウダキ	Presser bar holder	1	1
H 136		M91506001	トメネジ 15/64(28)X6	Screw 15/64(28)X6	1	1
H 137		MF10A0267	オサエボウメタル	Bushing	1	1
H 138		MS03A0262	オサエボウ	Presser bar	1	1
H 139		M90922002	ヒラネジ 9/64(40)X8	Screw 9/64(40)X8	1	1
H 140		MB62A0626	ニートルガード	Needle guard	1	1
H 141		MV30A0256	オサエ φ3	Presser foot φ3	1	1
H 142		ME10A1252	オサエアケレバ	Lifting lever	1	1
H 143		MF70A0350	イトユルメカム	Plate cam	1	1
H 144		M91504031	ホルトダンツキ 15/64(28)	Bolt 15/64(28)	1	1
H 145		M90423060	イトユルピン	Pin	1	1
H 146		M91131002	ヒラネジ 11/64(40)X6.5	Screw 11/64(40)X6.5	1	1
H 147		M91219015	ヒラネジダンツキ 3/16(28)	Screw 3/16(28)	2	2
H 148		ME45A0738	ヒキボウ	Link	1	1
H 149		ME25A0477	ストップ	Stopper	1	1
H 150		M95003017	セフティソケット M5X8	Bolt M5X8	2	2
H 151		ME25A0601	トリツケイタ	Adapter	1	1
H 152		ME25A0571	ジョイント	Joint	1	1
H 153		M95006017	セフティソケット M5X22	Bolt M5X22	2	2
H 154		ME40A0571	ワシタツツキテ	Connector	2	2
H 155		ME25A0434	エアシリンダ	Air cylinder	1	1
H 156		ME25A1454	ジク	Shaft	1	1
H 157		M95004020	ロッカクアナツキトメネジ M5X8	Screw M5X8	1	1
H 901		MG30A0760	ヘンシンリンクミタテ	Eccentric cam assy	1	1
H 902		MS02A0463	ウデ (ミキ)	Arm (right)	1	1

J 糸切り機構
THREAD TRIMMING MECHANISM

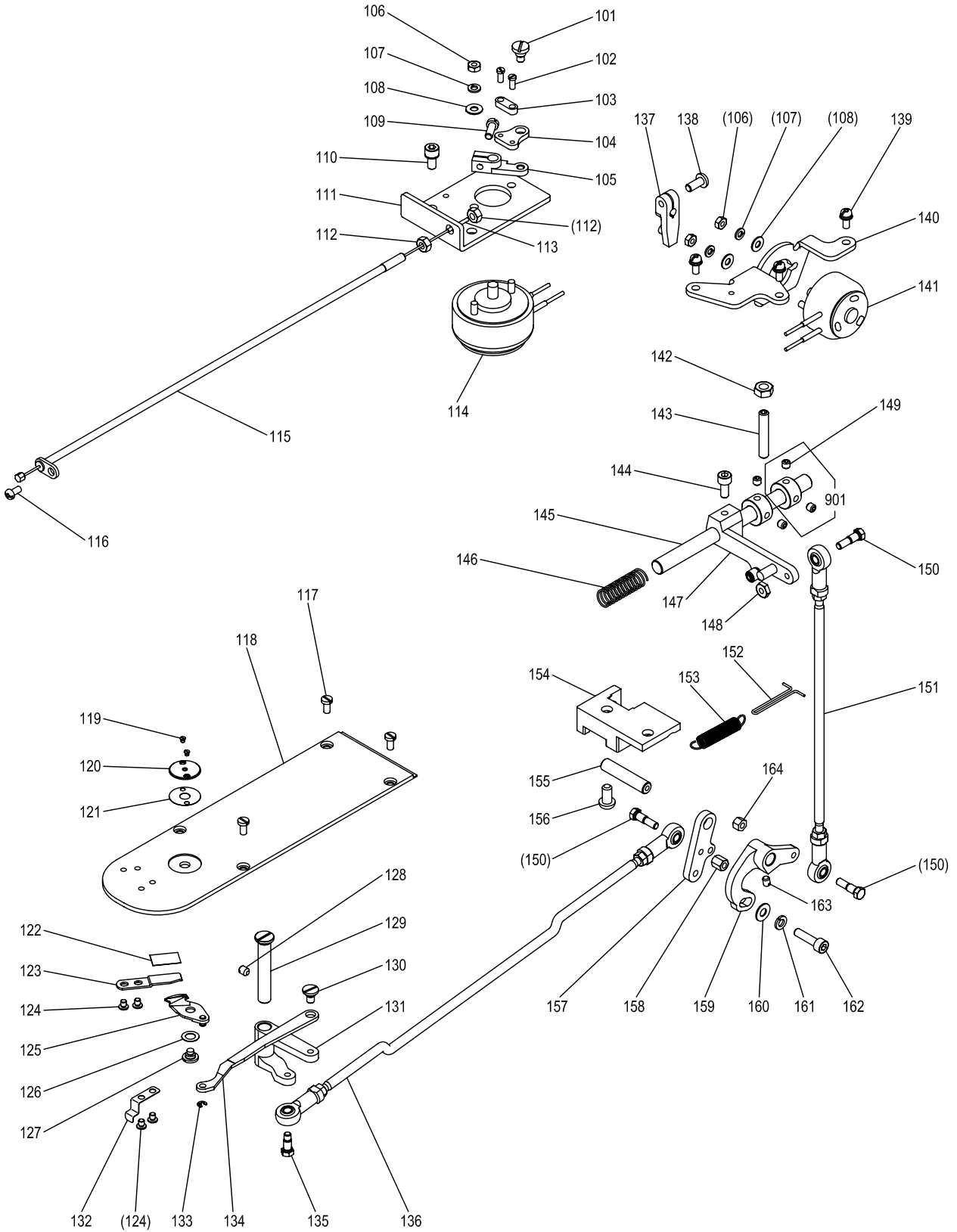

[J]糸切り機構

THREAD TRIMMING MECHANISM

Fig no.	変更 Mod.	部品コード Parts no.	品名	Description	数量	
					Amt. 4519	Req. 6019
J 101	M91127015		ヒラネジ ^ダ ンツキ 11/64(40).....	Screw 11/64(40).....	1	1
J 102	M90825002		ヒラネジ ^シ 1/8(44)X10.....	Screw 1/8(44)X10.....	2	2
J 103	MF36A0750		ホルダ.....	Holder.....	1	1
J 104	MF90A0361		カケガネ.....	Bracket.....	1	1
J 105	MS07A0228		ウデ.....	Crank.....	1	1
J 106	M91007045		ナット M4.....	Nut M4.....	4	4
J 107	M90424053		ハネサ ^ガ ネ 4.....	Spring washer 4.....	4	4
J 108	M90422050		サ ^ガ ネ 4.....	Washer 4.....	4	4
J 109	M91112002		ヒラネジ ^シ 11/64(40)X12.....	Screw 11/64(40)X12.....	1	1
J 110	MN60A0750		プッシュ.....	Pipe.....	1	1
J 111	MA20A0603		ソレノイド ^ト リツケイタ.....	Solenoid bracket.....	1	1
J 112	M91382045		ナット M5.....	Nut M5.....	2	2
J 113	M95005017		セフティソケット M5X10.....	Bolt M5X10.....	2	2
J 114	ME45E0519		イトルメソレノイド.....	Solenoid (thread release).....	1	1
J 115	ME45E0746		フレキシブルワイヤ.....	Flexible wire assy.....	1	1
J 116	M91054004		プラマイナ ^ヘ ネジ ^シ M4X8.....	Screw M4X8.....	1	1
J 117	M90990002		ヒラネジ ^シ M4X8.....	Screw M4X8.....	4	4
J 118	MB45A0472		スベ ^リ イタ.....	Slide plate.....	1	1
J 119	M90605010		サラネジ ^シ 3/32(56)X2.8.....	Screw 3/32(56)X2.8.....	2	2
J 120	MS03A1101		ハリイタ φ2.2.....	Needle plate.....	1	1
J 121	MS01A1476		スベ ^ー サ.....	Spacer.....	1	1
J 122	MA10B2476		スベ ^ー サ.....	Spacer.....	1	1
J 123	MS14A0838		コテイメス.....	Fixed knife.....	1	1
J 124	M90906003		マルヒラネジ ^シ 9/64(40)X3.2.....	Screw 9/64(40)X3.2.....	4	4
J 125	MS03B0838		イト ^ウ メス.....	Movable knife.....	1	1
J 126	M96004052		ウェーブワッシャ 6.....	Wave washer 6.....	1	1
J 127	M91129015		ヒラネジ ^ダ ンツキ 11/64(40).....	Screw 11/64(40).....	1	1
J 128	M91224001		トメネジ ^シ M5X8.....	Screw M5X8.....	1	1
J 129	MB62A0454		ツバ ^ツ キジク.....	Stepped pin.....	1	1
J 130	M91214015		ヒラネジ ^ダ ンツキ 3/16(28).....	Screw 3/16(28).....	1	1
J 131	MA20A0392		メス ^ク ト ^ウ ウデ ^シ (3).....	knife driving crank (3).....	1	1
J 132	MS01A0192		イタ ^ハ ネ.....	Leaf spring.....	1	1
J 133	M90513065		E ^ガ タ ^メ ワ 2.5.....	E-type retaining ring 2.5.....	1	1
J 134	MA20A1910		リンク.....	Link.....	1	1
J 135	M91101017		ホル ^ト ンツキ 11/64(40).....	Bolt 11/64(40).....	1	1
J 136	MB45E0975		ロ ^ッ ト ^エ ン ^ド クミ ^タ テ (ヨコ).....	Connecting rod (horizontal).....	1	1
J 137	MS01E0430		イ ^キ リサ ^ト ウ ^ウ デ.....	Crank.....	1	1
J 138	M95049021		ロ ^ッ カ ^ク ア ^ナ ツ ^キ ホ ^ト ン ^ボ ルト M5X12.....	Molt M5X12.....	1	1
J 139	M91056004		SW-PW ^ラ マイ ^ナ ヘ ^ネ ジ ^シ M4X10.....	Screw M4X10.....	3	3
J 140	MS14A3601		ソレノイド ^ト リツケイタ.....	Solenoid bracket.....	1	1
J 141	ME45E1519		イ ^キ リソ ^レ ノ ^イ ド.....	Solenoid (thread trim).....	1	1
J 142	M91576045		ナット M6.....	Nut M6.....	1	1
J 143	M91652020		コ ^ネ ジ ^シ M6X35.....	Screw M6X35.....	1	1
J 144	M95003021		ロ ^ッ カ ^ク ア ^ナ ツ ^キ ホ ^ト ン ^ボ ルト M5X12.....	Bolt M5X12.....	1	1
J 145	MS01A0348		カ ^ム ジ ^ク	Shaft.....	1	1
J 146	MS01A1572		ツ ^ル マ ^キ ハ ^ネ	Spring.....	1	1
J 147	MS01E0351		カ ^ム ツ ^イ ジ ^ユ ウ ^ウ デ ^ク ミ.....	Cam follower assy.....	1	1
J 148	M91104045		ナット 11/64(40).....	Nut 11/64(40).....	1	1
J 149	M95004021		ロ ^ッ カ ^ク ア ^ナ ツ ^キ ト ^メ ネ ^ジ ^シ M5X5.....	Screw M5X5.....	4	4
J 150	M90101017		ホル ^ト ンツキ 11/64(40).....	Bolt 11/64(40).....	3	3
J 151	MS01E0975		ロ ^ッ ト ^エ ン ^ド クミ ^タ テ (タテ).....	Connecting rod (vertical).....	1	1
J 152	MS08A0708		ハ ^ネ カ ^ケ	Hook.....	1	1
J 153	MS01A2572		ツ ^ル マ ^キ ハ ^ネ	Spring.....	1	1
J 154	MS14A3603		ト ^リ ツ ^ケ ダ ^イ	Bracket.....	1	1
J 155	MS01A4454		ジ ^ク	Shaft.....	1	1
J 156	M96062021		ロ ^ッ カ ^ク ア ^ナ ツ ^キ ホ ^ト ン ^ボ ルト M6X12.....	Bolt M6X12.....	2	2
J 157	MS01A2392		メス ^ク ト ^ウ ウ ^ウ デ ^シ (2).....	knife driving crank (2).....	1	1
J 158	M91109045		ロ ^ン グ ^ナ ット 11/64(40).....	Long nut 11/64(40).....	1	1
J 159	MS01A1392		メス ^ク ト ^ウ ウ ^ウ デ ^シ (1).....	knife driving crank (1).....	1	1
J 160	M90511050		サ ^ガ ネ 5.....	Washer 5.....	1	1
J 161	M90504053		ハ ^ネ サ ^ガ ネ 5.....	Spring washer 5.....	1	1
J 162	M95015021		ロ ^ッ カ ^ク ア ^ナ ツ ^キ ホ ^ト ン ^ボ ルト M5X20.....	Bolt M5X20.....	1	1
J 163	M91108001		ト ^メ ネ ^ジ ^シ 11/64(40)X5.5.....	Screw 11/64(40)X5.5.....	1	1
J 164	M91102045		ナット 11/64(40).....	Nut 11/64(40).....	1	1
J 901	MS01A3352		カ ^ラ ー ^ク ミ.....	Collar assy.....	2	2

From the library of: Diamond Needle Corp

K X-Yテーブル機構(1)
 X-Y TABLE MECHANISM(1)

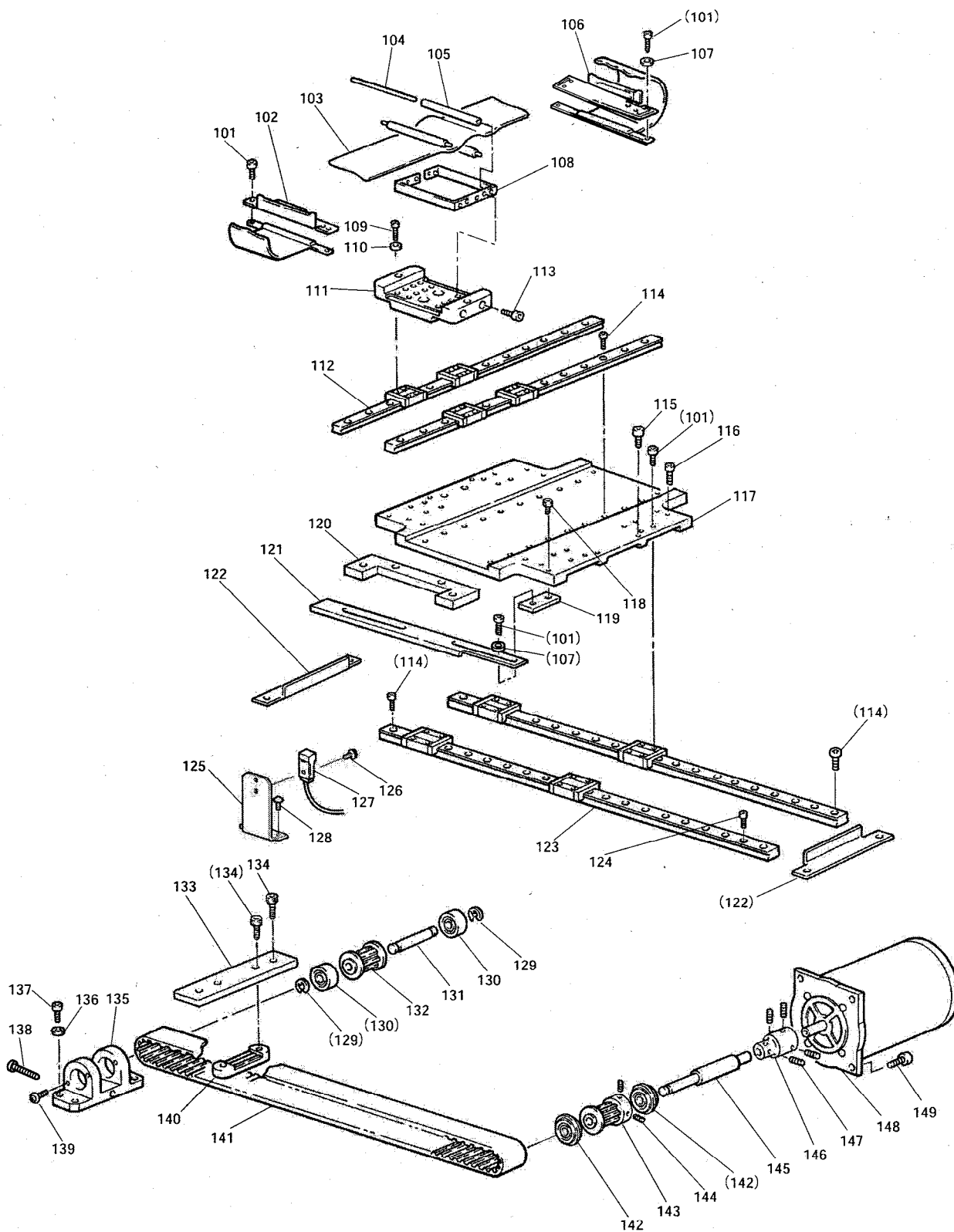

From the library of: Diamond Needle Corp

[K]X-Yテーブル機構(1)
WORK HOLDER MECHANISM(1)

Fig no.	変更 Mod.	部品コード Parts no.	品名	Description	数量	
					Amt. 4519	Req. 6019
K 101		M94003017	セフティソケット M3X6	Bolt M3X6	6	6
K 102		MA45A0477	Yジクストップ	Y stopper	1	1
K 103		MA45E0431	シートカバー (クミ)	Cover complete	1	1
K 104		MA46A0971	ローラジク	Shaft	3	3
K 105		MA46A0972	シートローラ	Roller	3	3
K 106		MA46A0477	Yジクストップ	Y stopper	1	1
K 107		M90316050	ザガネ 3	Washer 3	4	4
K 108		MA46A0359	ローラジクガイド	Roller guide	1	1
K 109		M90814004	プラマイナベネジ M3X5.2	Screw M3X5.2	16	16
K 110		M90317050	ザガネ 3	Washer 3	16	16
K 111		MA46A0957	Yジクイトウレース	Y-Movable race	1	1
K 112		MA20A5920	スライドガイド	Slide guide	2	2
K 113		M93003021	ロッカクアナツキホルト M3X6	Bolt M3X6	4	4
K 114		M93004021	ロッカクアナツキホルト M3X5	Bolt M3X5	30	30
K 115		M96001031	スペースホルト	Spacer bolt	8	8
K 116		M94005017	セフティソケット M3X10	Bolt M3X10	4	4
K 117		MB45A0957	Xジクイトウレース	X-Movable race	1	1
K 118		M94009017	セフティソケット M3X12	Bolt M3X12	2	2
K 119		MB45A0601	トリツケイタ	Adapter	2	2
K 120		MB45A1601	トリツケイタ	Adapter	1	1
K 121		MB45A0407	Xジクケンシュツイタ	Detector plate (X)	1	*
K 121		MB69A0407	Xジクケンシュツイタ	Detector plate (X)	*	1
K 122		MB45A0477	Xジクストップ	X-Stopper	2	*
K 122		MA61A0477	Xジクストップ	X-Stopper	*	4
K 123		MA45A3920	スライドガイド	Slide guide	2	*
K 123		MA61A2920	スライドガイド	Slide guide	*	2
K 124		M95013021	ロッカクアナツキホルト M3X10	Bolt M3X10	35	51
K 125		ME10A0408	ケンシュツタイ X	Detector bracket X	1	1
K 126		M90971004	SW-PWプラマイナベネジ M3X10	Screw M3X10	1	1
K 127		ME45A1484	キンセツスイッチ X	Detector X	1	1
K 128		M91054004	SW-PWプラマイナベネジ M4X8	Screw M4X8	2	2
K 129		M90604065	Eカク外メワ 8	E-type retaining ring 8	2	2
K 130		MS02A2456	ベアリング	Ball bearing	2	2
K 131		MA21P0454	ジク	Shaft	1	1
K 132		MB62A0767	タイミングプーリ	Cog pulley	1	1
K 133		MB45A2476	スペーサ	Spacer	1	1
K 134		M94001017	セフティソケット M4X10	Bolt M4X10	4	4
K 135		MA35A6758	ブラケット	Bracket	1	1
K 136		M90511050	ザガネ 5	Washer 5	4	4
K 137		M95001017	セフティソケット M5X20	Bolt M5X20	4	4
K 138		M95006021	ロッカクアナツキホルト M5X30	Bolt M5X30	1	1
K 139		M91071004	SW-MWプラマイナベネジ M4X8	Screw M4X8	4	4
K 140		MA45A0778	ベルトオサエ	Belt clamber	1	1
K 141		MB45A0523	タイミングベルト	Cog belt	1	*
K 141		MB69A0523	タイミングベルト	Cog belt	*	1
K 142		MB62A0456	ベアリング	Ball bearing	2	2
K 143		MB45A0767	タイミングプーリ	Cog pulley	1	1
K 144		M96001001	ロッカクアナツキメネジ M6X8	Screw M6X8	2	2
K 145		MA45A0390	Xクドウジク	Drive shaft	1	1
K 146		MA45A0571	ツギテ	Sleeve	1	1
K 147		M96002001	ロッカクアナツキメネジ M6X6	Screw M6X6	4	4
K 148		M95045095	ステッピングモータ X	Stepping motor X	1	1
K 149		M96004017	セフティソケット M6X20	Bolt M6X20	4	4

L X-Yテーブル機構(2)
 X-Y TABLE MECHANISM(2)

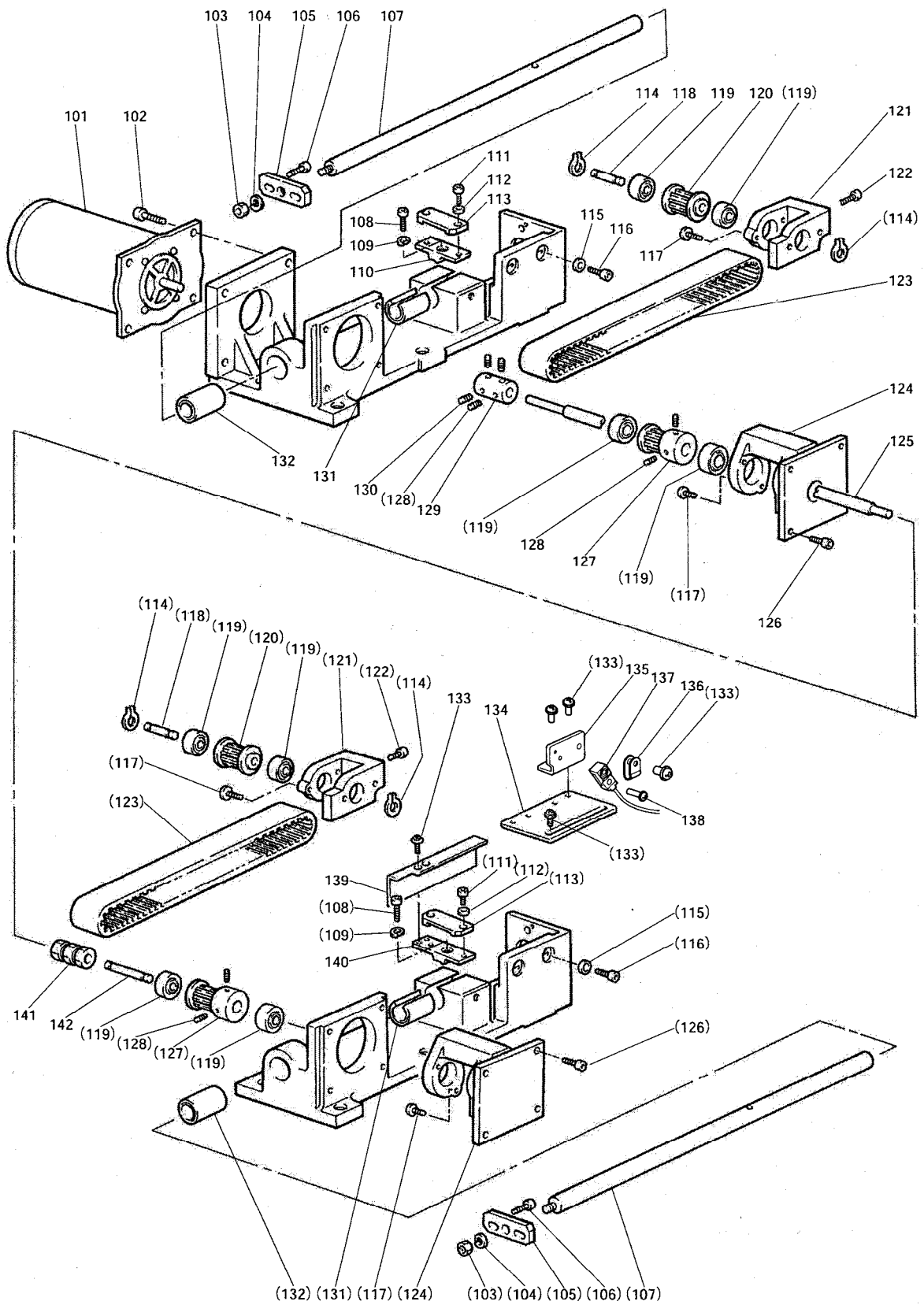

[L]X-Yテーブル機構(2)
WORK HOLDER MECHANISM(2)

Fig no.	変更 Mod.	部品コード Parts no.	品名	Description	数量	
					Amt. 4519	Req. 6019
L 101	M95046095		ステップモータ Y	Stepping motor Y	1	1
L 102	M96004017		セテソケット M6X20	Bolt M6X20	4	4
L 103	M92075045		ナット M8	Nut M8	2	2
L 104	M90803053		ハネサガネ 8	Spring washer 8	2	2
L 105	MA45A0751		ブロック	Block	2	2
L 106	M95002017		セテソケット M5X12	Bolt M5X12	4	4
L 107	MA45A1390		Yクドウシク	Drive shaft Y	2	2
L 108	M96061021		ロツカアナツキホルト M6X20	Bolt M6 x 20	2	2
L 109	M90624053		ハネサガネ 6	Spring washer 6	2	2
L 110	MA46A0781		Yベルトダイ (ヒダリ)	Y-Belt holfer (left)	1	1
L 111	M94001017		セテソケット M4X10	Bolt M4X10	4	4
L 112	M90422050		サガネ 4	Washer 4	4	4
L 113	MA45A1781		ベルトオサエ Y	Belt clasper Y	2	2
L 114	M90516065		Cガトメ 10	C-type retaining ring 10	4	4
L 115	M90511050		サガネ 5	Washer 5	4	4
L 116	M95001017		セテソケット M5X20	Bolt M5X20	4	4
L 117	M91071004		SW-PWプラマイナネジ M4X8	Screw M4X8	8	8
L 118	MS13A2454		シク	Shaft	2	2
L 119	MS02A2456		ベアリング	Ball bearing	8	8
L 120	MB62A0767		タイミングプーリ	Cog pulley	2	2
L 121	MS13A0758		ブラケット	Bracket	2	2
L 122	M95011021		ロツカアナツキホルト M5X25	Bolt M5X25	2	2
L 123	ME45A0523		タイミングベルト	Cog belt	2	2
L 124	MA45A5758		ブラケット	Bracket	2	2
L 125	MA45A2390		Yクドウシク	Drive shaft Y	1	1
L 126	M95004017		セテソケット M5X16	Bolt M5X16	8	8
L 127	MB45A0767		タイミングプーリ	Cog pulley	2	2
L 128	M96001001		ロツカアナツキメネジ M6X8	Screw M6X8	6	6
L 129	ME45A0571		シクツキテ	Sleeve	1	1
L 130	M96002001		ロツカアナツキメネジ M6X6	Screw M6X6	2	2
L 131	MA45A0921		リアブッシュ	Bearing	2	2
L 132	MA45A1921		リアブッシュ	Bearing	2	2
L 133	M91054004		SW-PWプラマイナネジ M4X8	Screw M4X8	7	7
L 134	MB45A2601		トリツケイタ	Adjuster plate	1	1
L 135	ME40A5601		ケンシュツキトリツケイタ	Detector adapter	1	1
L 136	M94003099		ナイロンクリップ AB-3N	Nylon clip AB-3N	1	1
L 137	ME45A0484		キンセツスイッチ Y	Detector Y	1	1
L 138	M90971004		SW-PWプラマイナネジ M3X10	Screw M3X10	1	1
L 139	ME45A0407		Yシクケンシュツイタ	Detector plate Y	1	1
L 140	MA46A2781		Yベルトダイ (ミキ)	Y-Belt holder (right)	1	1
L 141	MB45A0364		カップリンク	Coupring	1	1
L 142	MB45A0390		Yクドウシク	Drive shaft Y	1	1

M 外押え機構
 WORK HOLDER MECHANISM

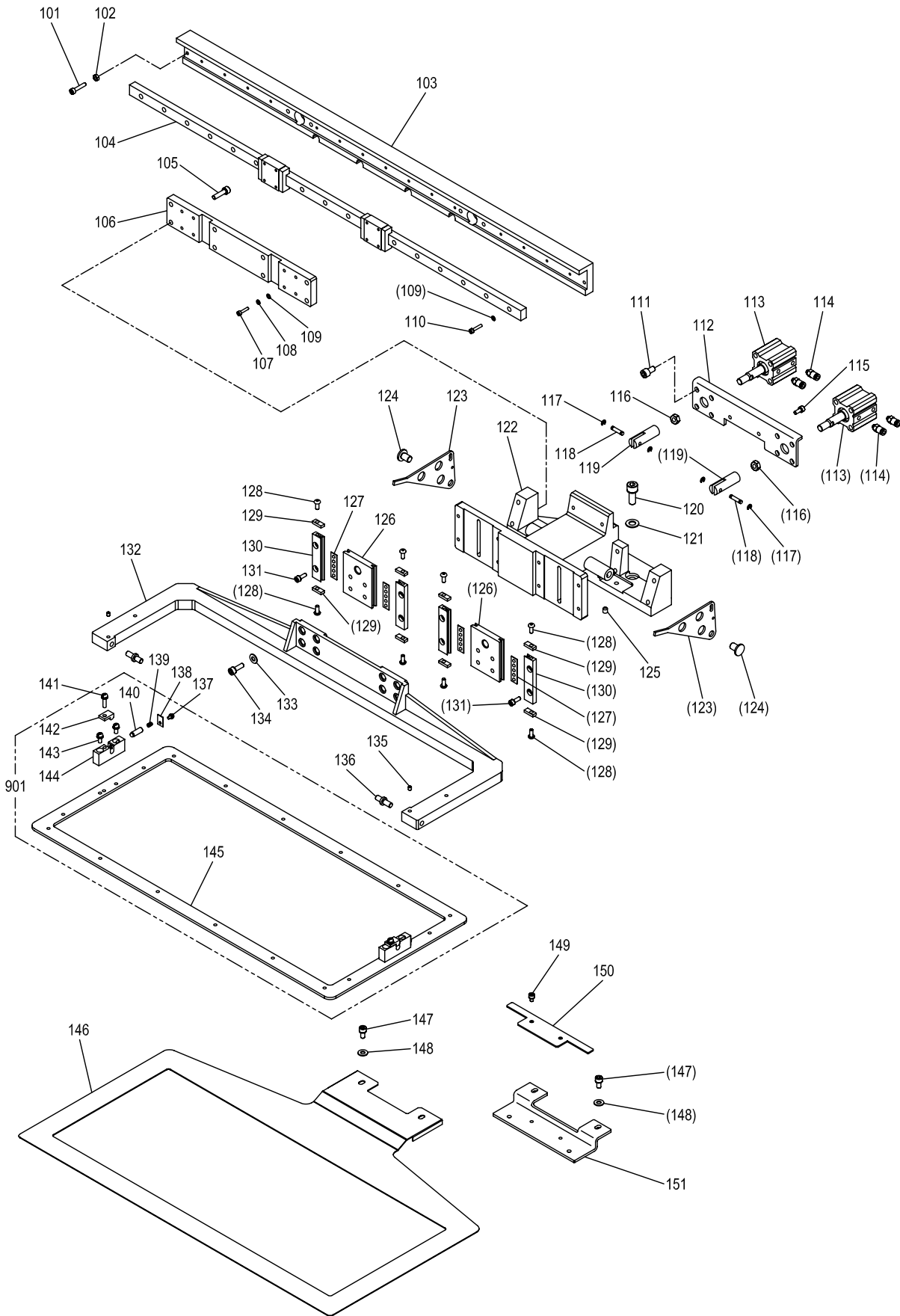

[M]外押え機構

WORK HOLDER MECHANISM

Fig no.	変更 Mod.	部品コード Parts no.	品名	Description	数量	
					Amt. 4519	Req. 6019
M 101		M94015021	ロッカアナツキホルト M4X20	Bolt M4X20	2	2
M 102		M91007045	ナット M4	Nut M4	2	2
M 103		MA45A0455	ジクササエ	Shaft holder	1	*
M 103		MA61A0455	ジクササエ	Shaft holder	*	1
M 104		MB45A1920	スライドガイド	Slide guide	1	*
M 104		MB69A1920	スライドガイド	Slide guide	*	1
M 105		M95001017	セフティソケット M5X20	Bolt M5X20	8	8
M 106		MA45A1601	トリツケイタ	Adapter	1	1
M 107		M93020021	ロッカアナツキホルト M3X14	Bolt M3X14	8	8
M 108		M90307053	ハネサガネ 3	Spring washer 3	8	8
M 109		M90317050	サガネ 3	Washer 3	23	27
M 110		M94004017	セフティソケット M3X16	Bolt M3X16	15	19
M 111		M96002017	セフティソケット M6X12	Bolt M6X12	8	8
M 112		MA45A2601	トリツケイタ	Adapter	1	1
M 113		MA45A0434	エアシリンダ	Air cylinder	2	2
M 114		MA20A9571	ワナツツツキテ	Connector	4	4
M 115		M94016017	セフティソケット M4X10	Bolt M4X10	2	2
M 116		M92075045	ナット M8	Nut M8	2	2
M 117		M90512065	Eタイプメワ 3	E-type retaining ring 3	4	4
M 118		M90327060	ピン	Pin	2	2
M 119		MA45A0621	ナックル	Knuckle	2	2
M 120		M98004017	セフティソケット M8X20	Bolt M8X20	2	2
M 121		M90825050	サガネ 8	Washer 8	2	2
M 122		MA45A0308	オサエダイ	Clamp bracket	1	1
M 123		MA45A0266	オサエレバ	Pushing lever	2	2
M 124		MB61A3454	ツバツキジク	Shaft	2	2
M 125		M91050020	ロッカアナツキメネジ M4X5	Bolt M4X5	2	2
M 126		MB45A1957	オサエイトレース	Movable race	2	2
M 127		M94008070	ローラーケージ	Roller cage	4	4
M 128		M94016021	ロッカアナツキホルト M4X8	Bolt M4X8	8	8
M 129		MS13A2477	ストップパ	Stopper	8	8
M 130		MA22A0957	オサエコテイレース	Fixed race	4	4
M 131		M94002017	セフティソケット M4X8	Bolt M4X8	8	8
M 132		MA45A0273	オサエウテ	Clamp adapter	1	*
M 132		MA61A0273	オサエウテ	Clamp adapter	*	1
M 133		M90512050	サガネ 5	Washer 5	8	8
M 134		M95004017	セフティソケット M5X16	Bolt M5X16	8	8
M 135		M91053020	ロッカアナツキメネジ M4X6	Bolt M4X6	2	2
M 136		ME40A0454	オサエシク	Clamp stud	2	2
M 137		M90859004	SW-PWフライナメネジ M3X6	Screw M3X6	2	2
M 138		MS02B0257	オサエイタ	Adapter	2	2
M 139		MS13A0572	コイルハネ	Spring	2	2
M 140		M90611060	ピン	Pin	2	2
M 141		M91073004	SW-PWフライナメネジ M4X16	Screw M4X16	2	2
M 142		MA45A2196	セットイタ	Set plate	2	2
M 143		M91056004	SW-PWフライナメネジ M4X10	Screw M4X10	4	4
M 144		MA45A7426	ササエ	Supporter	2	2
M 145		MA46A0105	ソトオサエイタ	Clamp frame	1	*
M 145		MA61A0105	ソトオサエイタ	Clamp frame	*	1
M 146		MA46A0272	シタオサエイタ	Feed plate	1	*
M 146		MA61A0272	シタオサエイタ	Feed plate	*	1
M 147		M95005017	セフティソケット M5X10	Bolt M5X10	4	4
M 148		M90511050	サガネ 5	Washer 5	4	4
M 149		M94008017	セフティソケット M4X6	Bolt M4X6	2	2
M 150		MA45A0196	セットイタ	Set plate	1	1
M 151		MA45A3601	トリツケイタ	Adapter	1	1
M 901		MA46E0105	ソトオサエクミ	Clamp frame assy	1	*
M 901		MA61E0105	ソトオサエクミ	Clamp frame assy	*	1

From the library of: Diamond Needle Corp

N ワイパー機構
WIPER MECHANISM

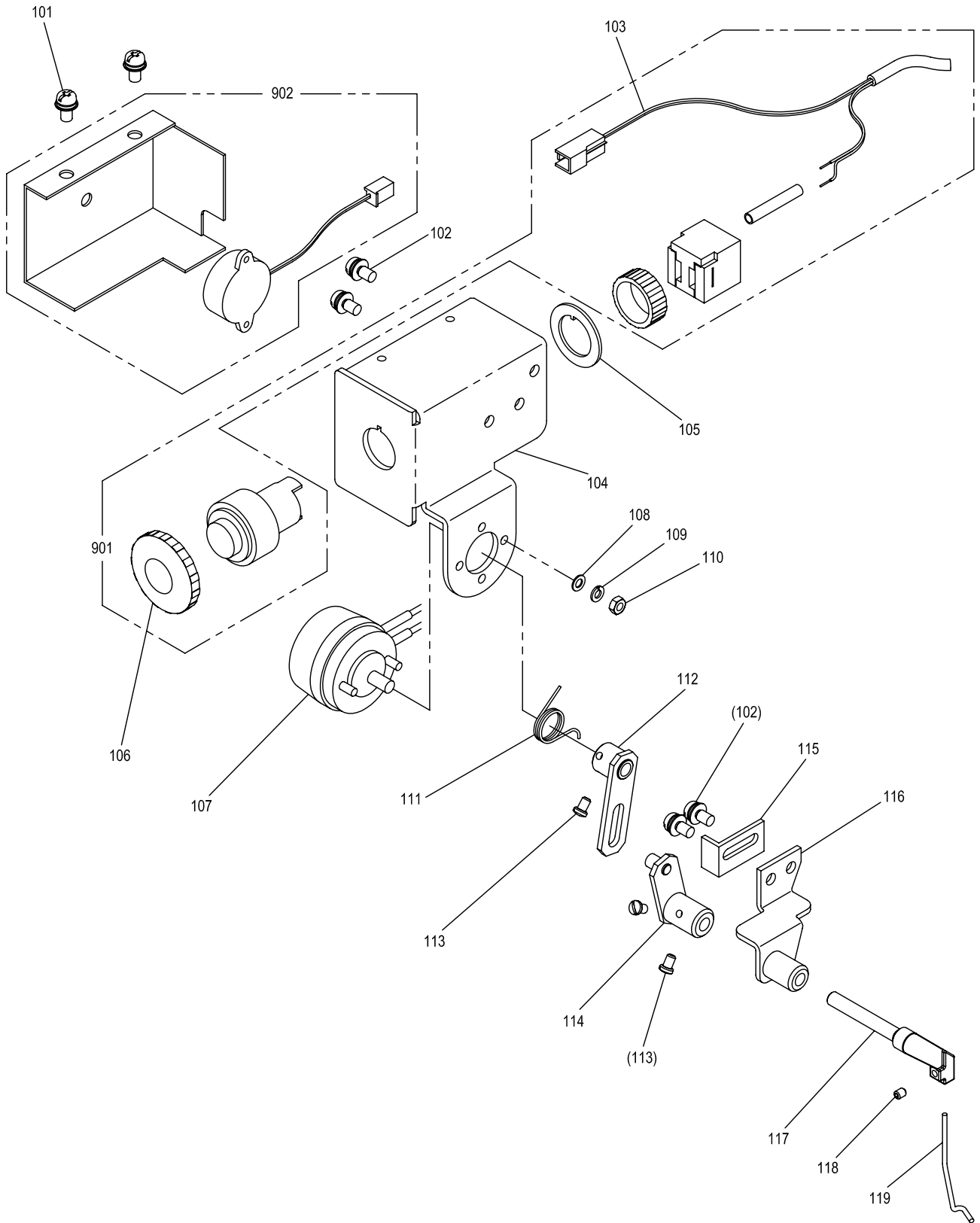

[N]ワイパー機構
WIPER MECHANISM

Fig no.	変更 Mod.	部品コード Parts no.	品名	Description	数量	
					Amt. Req. 4519	6019
N 101		M91054004	SW-PWプラマイナヘネジ M4X8	Screw M4X8	2	2
N 102		M91056004	SW-PWプラマイナヘネジ M4X10	Screw M4X10	4	4
N 103		ME45A0508	セツクテンセン	Cable (stop BZ)	1	1
N 104		ME10E3601	トリツケイタ	Bracket	1	1
N 105		MB60A0915	ロックリング	Lock ring	1	1
N 106		ME03A0270	プッシュボタン	Push button	1	1
N 107		ME45E2519	ワイパーソレノイド	Solenoid (wiper)	1	1
N 108		M90317050	ザガネ 3	Washer 3	2	2
N 109		M90307053	ハネザガネ 3	Spring washer 3	2	2
N 110		M90875045	ナット M3	Nut M3	2	2
N 111		MS02A4729	ヒネリハネ	Spring	1	1
N 112		MS02E0983	クツウイタ	Wiper crank 1	1	1
N 113		M90802003	マルヒラネジ 1/8(44)X4.5	Screw 1/8(44)X4.5	4	4
N 114		MB61A0436	ジュウトウイタ	Wiper crank 2	1	1
N 115		MS02A1477	ストッパ	Stopper	1	1
N 116		MS10A0982	ワイパーダイ	Wiper adapter	1	1
N 117		MS03A1530	ワイパーシャフト	Wiper shaft	1	1
N 118		M91057020	ロッククアナツキメネジ M3X4	Screw M3X4	1	1
N 119		MA20A0980	ワイパー	Wiper	1	1
N 901		ME45E0270	オンボタンスイッチミ	Switch assy	1	1
N 902		MB60E3339	カバークミ (ブザーツキ)	Cover assy (with buzzer)	1	1

P 給油機構
OIL LUBRICATION MECHANISM

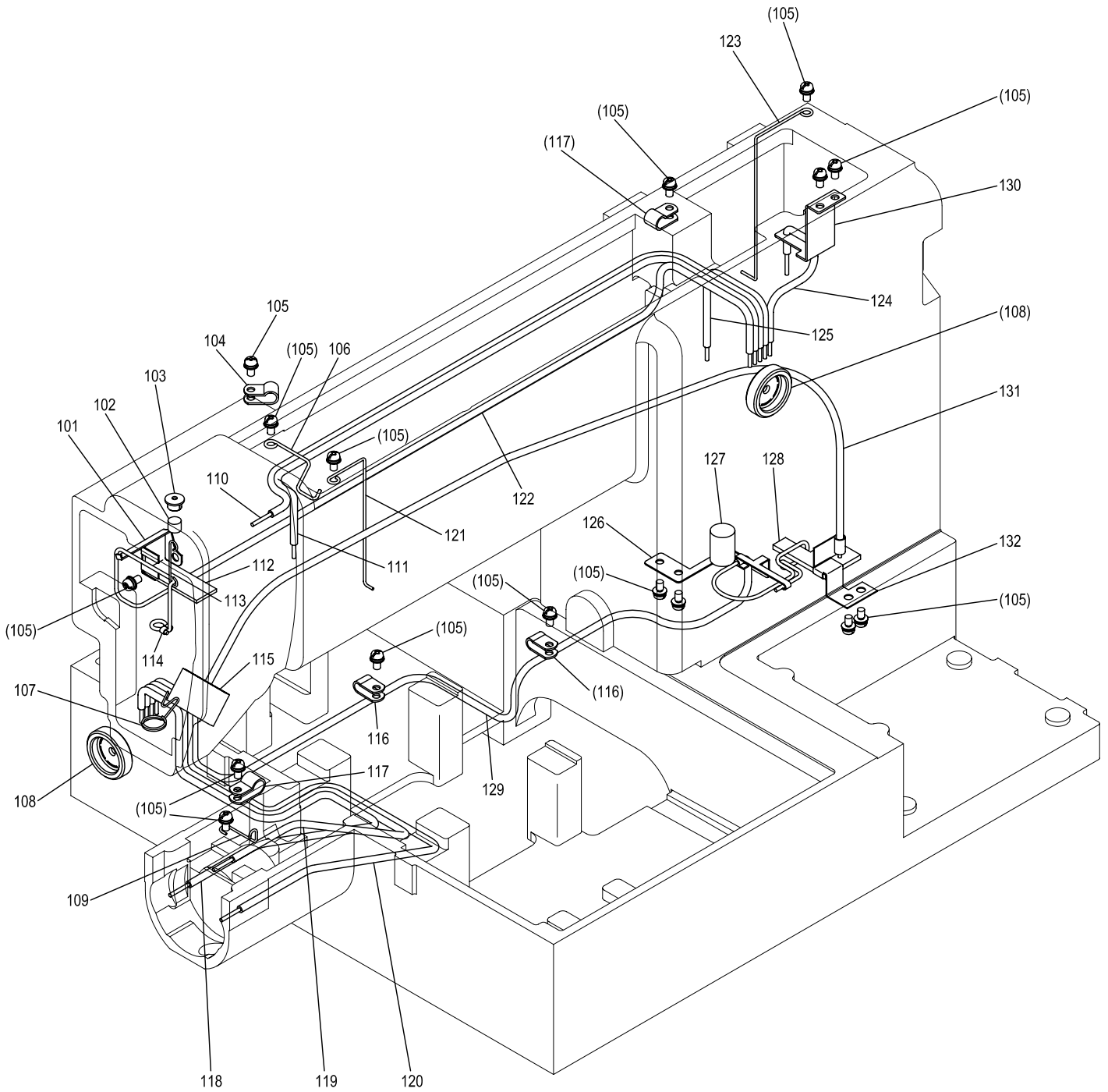

From the library of: Diamond Needle Corp

[P]給油機構

OIL LUBRICATION MECHANISM

Fig no.	変更 Mod.	部品コード Parts no.	品 名	Description	数量	
					Amt. Req. 4519	6019
P 101		ME10A1780	ホルダ	Holder	1	1
P 102		MF10A2740	フェルト	Felt	1	1
P 103		MF60A0742	フタ	Cap	1	1
P 104		MS14A1620	ナイロンクリップ AB-4N	Nylon clip AB-4N	1	1
P 105		M91054004	SW-PWプラマイナネジ M4X8	Screw M4X8	16	16
P 106		MA20A1780	ホルダ	Holder	1	1
P 107		MF00A2780	ホルダ	Holder	1	1
P 108		MN10A0135	オイルゲージ	Oil gauge	2	2
P 109		MS01A8796	ホルダ	Holder	1	1
P 110		ME45E0688	パイプヒモクミ (ウワシクメタル マエ)	Oil pipe assy (drive shaft bushing F)	1	1
P 111		ME45E1688	パイプヒモクミ (ハンシンリン)	Oil pipe assy (eccentric cam)	1	1
P 112		MS01A1740	フェルト	Felt	1	1
P 113		MS03A2780	ホルダ	Holder	1	1
P 114		MF80A0780	ホルダ	Holder	1	1
P 115		MS01A0740	フェルト	Felt	1	1
P 116		M94003099	ナイロンクリップ AB-3N	Nylon clip AB-3N	2	2
P 117		MN60A0620	ナイロンクリップ AB-5N	Nylon clip AB-5N	2	2
P 118		ME45E2688	パイプヒモクミ (カマ ヒタリ)	Oil pipe assy (hook left)	1	1
P 119		MB45E1148	パイプヒモクミ (カマ ナカ)	Oil pipe assy (hook center)	1	1
P 120		ME45E3688	パイプヒモクミ (カマ ミキ)	Oil pipe assy (hook right)	1	1
P 121		MS10A0780	ホルダ	Holder	1	1
P 122		ME45E4688	パイプヒモクミ (ハリホウ)	Oil pipe assy (needle bar)	1	1
P 123		ME20A1780	ホルダ	Holder	1	1
P 124		MB62E0780	パイプヒモクミ (レンセツカン)	Oil pipe assy (connecting rod)	1	1
P 125		MA20E3688	パイプヒモクミ (ウワシクメタル ナカ)	Oil pipe assy (drive shaft bushing C)	1	1
P 126		MS14A3780	ホルダ	Holder	1	1
P 127		MF60A5740	フェルト	Felt	1	1
P 128		MS14A0740	フェルト	Felt	1	1
P 129		MB45A1780	パイプヒモクミ (シタシクメタル ウシロ)	Oil pipe assy (hook shaft bushing R)	1	1
P 130		MB60A1780	ホルダ	Holder	1	1
P 131		MB45E2148	パイプヒモクミ (カンユ)	Oil pipe assy (circulation)	1	1
P 132		MS01A9796	ホルダ	Holder	1	1

Q 配線検出器関係
CABLE COMPONENT & PNEUMATIC CONTRPL UNIT

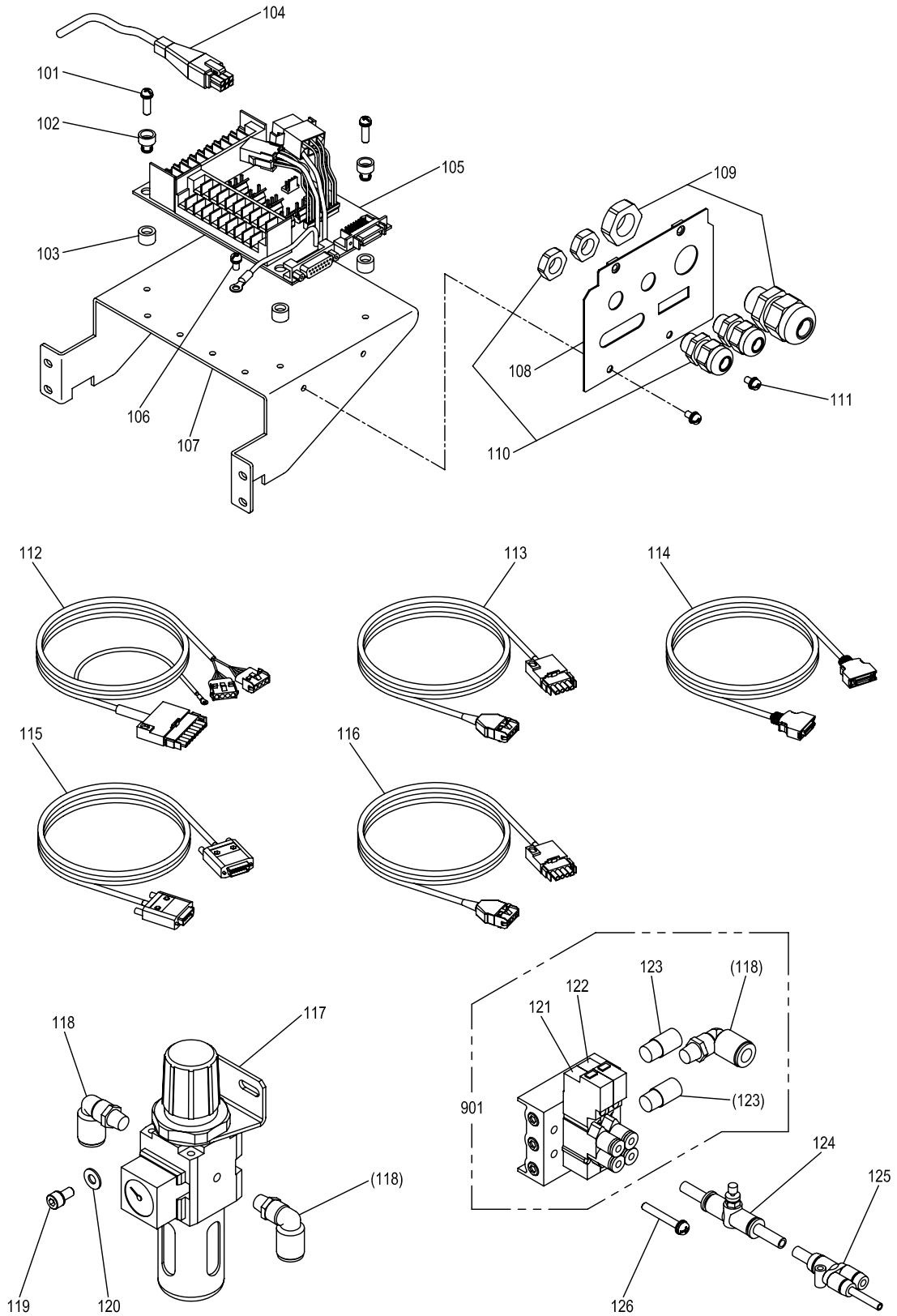

[Q]配線・配管関係

CABLE COMPONENT & PNEUMATIC CONTROL UNIT

Fig no.	変更 Mod.	部品コード Parts no.	品 名	Description	数量	
					Amt. Req. 4519	6019
Q 101		M91057004	SW-PWブラマイナヘネジ M4X20	Screw M4X20	4	4
Q 102		MB60A0366	ワシタツチブツシュ	Nylon bush	4	4
Q 103		MB60A2352	ワシタツチブツシュ	Nylon bush	4	4
Q 104		K14M71725402	ケーブル (エンコーダ)	Cable (Encoder)	1	1
Q 105		M800E1CON	Pバンクミタテ PLK-E-CON	Print circuit board	1	1
Q 106		M90439037	SWブラマイナヘネジ M4X8	Screw M4X8	1	1
Q 107		ME45A0601	Pハントリツケイタ	Circuit board bracket	1	1
Q 108		MB45A4601	コネクタトリツケイタ	Connector panel	1	1
Q 109		MB60A5780	コードブツシュ ダイ	Cord bushing (large)	1	1
Q 110		MB60A6780	コードブツシュ ショウ	Cord bushing (small)	2	2
Q 111		M91054004	SW-PWブラマイナヘネジ M4X8	Screw M4X8	2	2
Q 112		M97321099	ケーブル (ステッピングモータ)	Cable (stepping motor)	1	1
Q 113		ME40A1508	ケーブル (ステッピングモータエンチャウヨウ)	Cable (stepping motor extension)	1	1
Q 114		M97319099	ケーブル (ニューリヨクシンゴウ)	Cable (input signal)	1	1
Q 115		M97320099	ケーブル (ソレノイド)	Cable (solenoid)	1	1
Q 116		M97318099	ケーブル (サーボモータテンケン)	Cable (servo motor)	1	1
Q 117		MB61A0963	フィルタレキユレータ	Filter regulator	1	1
Q 118		MA20A8571	Lカタツキテ	L-type quick joint	3	3
Q 119		M95003017	セフテイソケット M5X8	Bolt M5X8	2	2
Q 120		M90511050	ザガネ 5	Washer 5	2	2
Q 121		MB62A1599	デンジベン (ナカオサエ)	Solenoid valve (presser bar lifting)	1	1
Q 122		MB62A2599	デンジベン (ソオサエ)	Solenoid valve (work holder)	1	1
Q 123		M91035089	サイレンサ	Muffler	2	2
Q 124		MA20A6571	イケイユニオンY	Y-type quick joint	2	2
Q 125		MA16A0495	スピードコントローラ	Speed controller	2	2
Q 126		M91276004	SW-PWブラマイナヘネジ M4X30	Screw M4X30	4	4
Q 901		MB45E0599	デンジベンクミタテ	Solenoid valve complete	1	1

R テーブル関係
TABLE & STAND

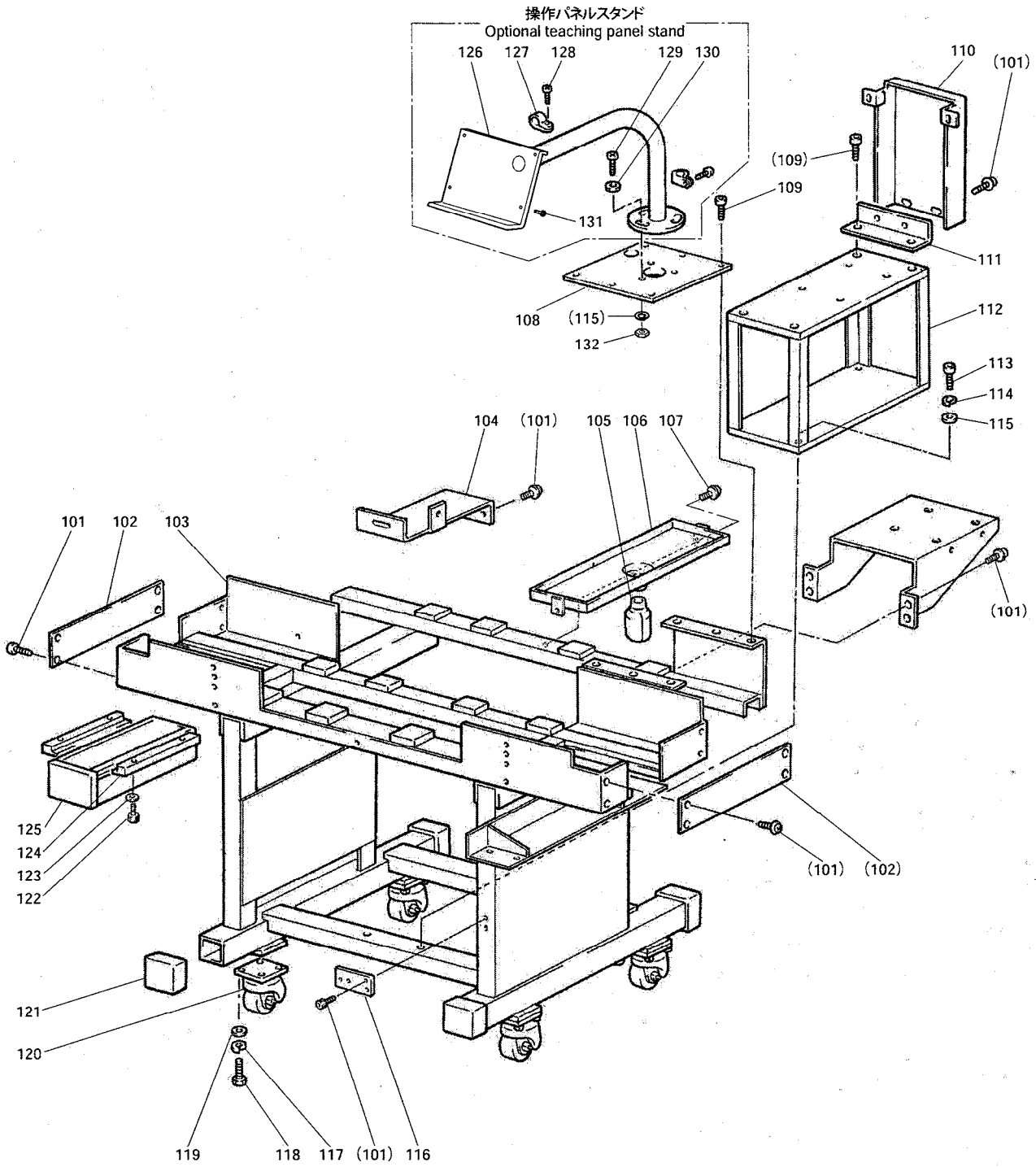

[R]テーブル関係
TABLE & STAND

Fig no.	変更 Mod.	部品コード Parts no.	品名	Description	数量	
					Amt. 4519	Req. 6019
R 101		M94013017	セフテソケット M4X12	Bolt M4X12	21	21
R 102		MB45A3339	カバー	Cover	2	2
R 103		MB45E0150	キャククミタテ	Table	1	*
R 103		MB69E0150	キャククミタテ	Table	*	1
R 104		MB45A2339	カバー	Cover	1	1
R 105		MF20A0130	アブラビン	Oil bottle	1	1
R 106		MB45A0139	オイルパン	Oil pan	1	1
R 107		M91058004	SW-PWプラマイナヘネジ M4X6	Screw M4X6	2	2
R 108		ME45A1601	スタントトリツケイタ	Adapter	1	1
R 109		M95010017	セフテソケット M5X12	Bolt M5X12	8	8
R 110		MB45A0776	ベルトカバー	Belt cover	1	1
R 111		MA35B7601	ベルトカバートリツケイタ	Adapter	1	1
R 112		MB45A0603	モーターリツケタイ	Motor adapter	1	1
R 113		M96009021	ロッククアナツキホルト M6X16	Bolt M6X16	4	4
R 114		M90624053	ハネザガネ 6	Spring washer 6	4	4
R 115		M90631050	ザガネ 6	Washer 6	4	4
R 116		MB45A6601	レギュレーターリツケイタ	Adapter	1	1
R 117		M91003053	ハネザガネ 10	Spring washer 10	16	16
R 118		M91016022	ロッククホルト M10X25	Bolt M10X25	16	16
R 119		M91012050	ザガネ 10	Washer 10	16	16
R 120		MB45E0972	キャスト	Castor	4	4
R 121		MB45A0150	ゴムキャク	Top cap	4	4
R 122		M91066004	SW-PWプラマイナヘネジ M4X25	Screw M4X25	4	4
R 123		M90421050	ザガネ 4	Washer 4	4	4
R 124		MB60A3957	レール	Rail	2	2
R 125		MA20A0719	ヒキダシ	Drawer	1	1
R 126		ME45A0770	スタントベース	Panel stand base	1	1
R 127		MS14A1620	ナイロンクリップ AB-4N	Nylon clip AB-4N	2	2
R 128		M91054004	SW-PWプラマイナヘネジ M4X8	Screw M4X8	2	2
R 129		M96061021	ロッククアナツキホルタンホルト M6X20	Bolt M6X20	3	3
R 130		M90712050	ザガネ	Washer	3	3
R 131		M91056004	SW-PWプラマイナヘネジ M4X10	Screw M4X10	4	4
R 132		M91576045	ナット 6	Nut 6	3	3

S 付属品
ACCESSORIES

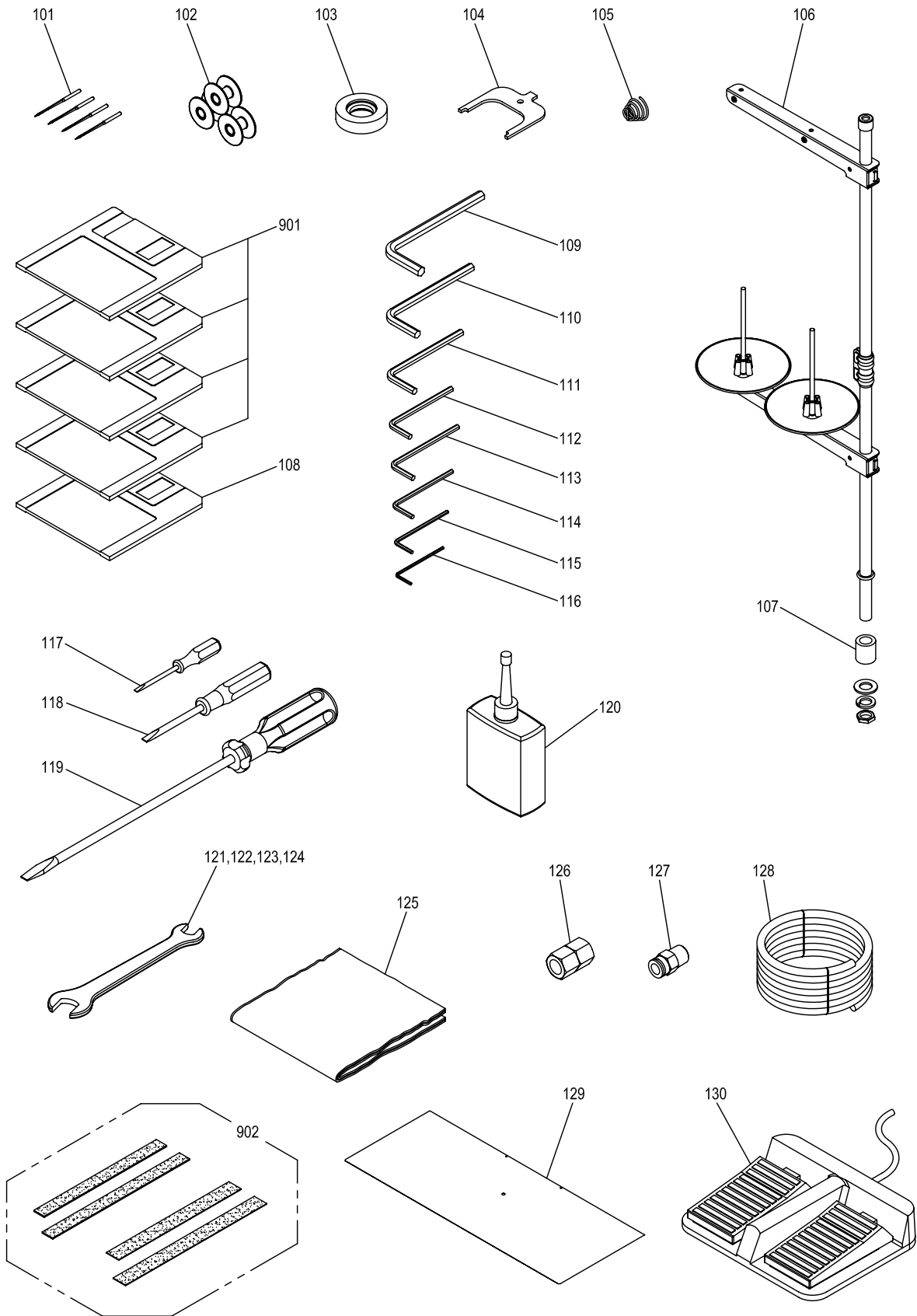

[S]付属品
ACCESSORIES

Fig no.	変更 Mod.	部品コード Parts no.	品名	Description	数量	
					Amt. Req. 4519	6019
S 101		MS02A0128	ミシンハリ DPX17#18	Needle DPX17#18	4	4
S 102		MA10A0123	ホビン	Bobbin	3	3
S 103		MS03A0417	ゴムワ (イトマキヨウ)	Tire (for bobbin winder)	1	1
S 104		MF01A0565	カク ^レ チヨウセイグ	Speed command disk adjusting plate	1	1
S 105		MN52A1245	エンスイバネ	Tension spring	1	1
S 106		MF40E0193	イトタテダイミタテ	Cotton stand assy	1	1
S 107		MA30A0352	イトタテダイカラー	Cotton stand collar	1	1
S 108		MB60A1990	デー ^レ タフロッピ ^レ イディスク	Pattern data F/D	1	1
S 109		MS05A1976	ロツカクホ ^レ ウレンチ 6	Hexagonal wrench 6	1	1
S 110		MS05A0976	ロツカクホ ^レ ウレンチ 5	Hexagonal wrench 5	1	1
S 111		MS01A1976	ロツカクホ ^レ ウレンチ 4	Hexagonal wrench 4	1	1
S 112		MF90A0976	ロツカクホ ^レ ウレンチ 1/8"	Hexagonal wrench 1/8"	1	1
S 113		MS02A2976	ロツカクホ ^レ ウレンチ 3	Hexagonal wrench 3	1	1
S 114		MS02A1976	ロツカクホ ^レ ウレンチ 2.5	Hexagonal wrench 2.5	1	1
S 115		MS02A0976	ロツカクホ ^レ ウレンチ 2	Hexagonal wrench 2	1	1
S 116		MS10A0976	ロツカクホ ^レ ウレンチ 1.5	Hexagonal wrench 1.5	1	1
S 117		MB02A1608	ドライバ ^レ (ショウ)	Screw driver (small)	1	1
S 118		MB02A0608	ドライバ ^レ (チュウ)	Screw driver (middle)	1	1
S 119		MF00A0608	ドライバ ^レ (ダイ)	Screw driver (large)	1	1
S 120		MF10A0149	アブラサシ	Oiler with oil	1	1
S 121		MS02A0479	スパナ 13-17	Spanner 13-17	1	1
S 122		MM10A1479	スパナ 10-14	Spanner 10-14	1	1
S 123		MS10A1976	スパナ 8-9	Spanner 8-9	1	1
S 124		MS10A2976	スパナ 6-7	Spanner 6-7	1	1
S 125		MA20A0734	ビニルカバー	Polyethylene cover	1	1
S 126		M91010089	ロツカクソケット	Socket	1	1
S 127		MA30A0571	ワシタツツキテ	Quick joint	1	1
S 128		MS06A0567	エアチューブ	Air tube	1	1
S 129		MA45A0797	ホコフィルム	Film sheet	1	*
S 129		MA61A0797	ホコフィルム	Film sheet	*	1
S 130		M860A0FSW	フットスイッチ	Foot switch	1	1
S 901		ME20E0990	システムフロッピ ^レ イディスク (4マイ)	System F/D (4discs)	1	1
S 902		ME45E0691	ハッキンセット	Clamp pad set	1	*
S 902		ME69E0691	ハッキンセット	Clamp pad set	*	1

T オプションパーツ
OPTION PARTS

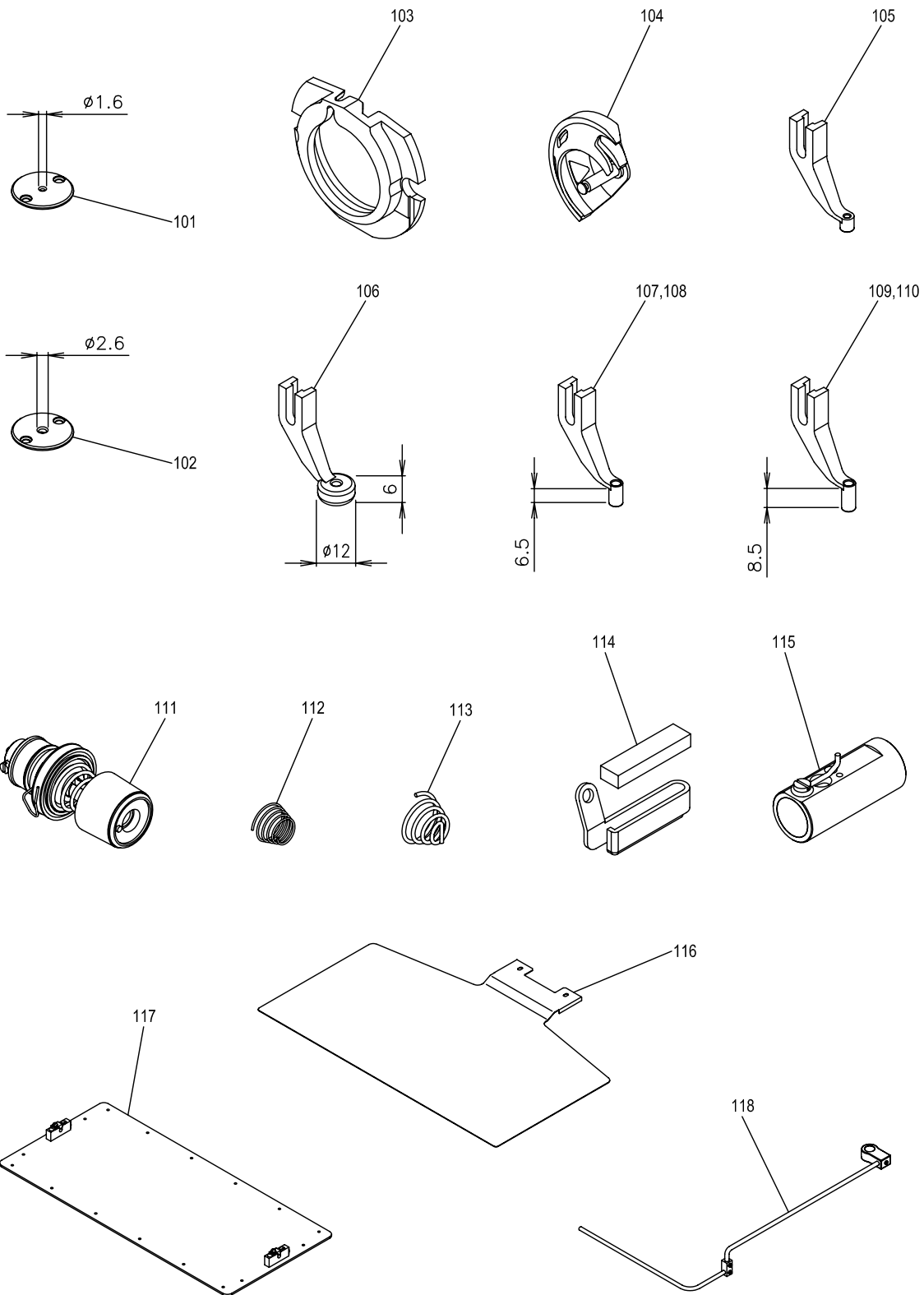

[T]オプションパーツ
OPTION PARTS

Fig no.	変更 Mod.	部品コード Parts no.	品 名	Description	数量	
					Amt. Req. 4519	6019
T 101		MS03A0101	ハリタ (ウスモノヨウ) φ 1.6	Needle plate (for light) φ 1.6	1	1
T 102		MS03A2101	ハリタ (アツモノヨウ) φ 2.6	Needle plate (for heavy) φ 2.6	1	1
T 103		MS01A1616	ナカガマオサエ (アツモノヨウ)	Inner hook clamber (for heavy)	1	1
T 104		MS17A1120	ナカガマ (アツモノヨウ)	Inner hook (for heavy)	1	1
T 105		MV30A1256	ナカオサエ (ウスモノヨウ)	Presser foot (for light)	1	1
T 106		MV35A0106	サラオサエ	Presser foot	1	1
T 107		MS03A0256	ナカオサエ φ 3	Presser foot φ 3	1	1
T 108		MS03A1256	ナカオサエ φ 2	Presser foot φ 2	1	1
T 109		MA35A0256	ナカオサエ φ 3	Presser foot φ 3	1	1
T 110		MA35A1256	ナカオサエ φ 2	Presser foot φ 2	1	1
T 111		MS04E1210	ウワイトチョウセツキ (クミ)	Thread tension regulator assy	1	1
T 112		MF10A1245	エンスイハネ (プリテンションヨウ)	Spring (for pretension)	1	1
T 113		MN10A3245	エンスイハネ (ウワイトチョウセツキヨウ)	Spring (for thread tension regulator)	1	1
T 114		MS03A0181	イトアンナイ	Thread guide	1	1
T 115		MS10A0180	イトアンナイ	Thread guide	1	1
T 116		MA46A1272	シタオサエイタ (アナナシ)	Feed plate (blank)	1	*
T 116		MA61A1272	シタオサエイタ (アナナシ)	Feed plate (blank)	*	1
T 117		MA46E1105	ソトオサエクミタテ (アナナシ)	Clamp frame assy (blank)	1	*
T 117		MA61E1105	ソトオサエクミタテ (アナナシ)	Clamp frame assy (blank)	*	1
T 118		MA35A0180	イトアンナイ	Thread guide	1	1

索引
INDEX-1

部品コード Parts No.	ページ Page	Fig No.	部品コード Parts No.	ページ Page	Fig No.	部品コード Parts No.	ページ Page	Fig No.	部品コード Parts No.	ページ Page	Fig No.								
K14M71725402	...	P29	...	Q 104	M90815002	...	P11	...	F 131	M91057020	...	P7	...	D 115	M91689015	...	P15	...	H 107
M800E1CON	...	P29	...	Q 105	M90823050	...	P3	...	B 133	↑	...	P25	...	N 118	M91801035	...	P15	...	H 101
M860A0FSW	...	P33	...	S 130	M90825002	...	P17	...	J 102	M91058004	...	P31	...	R 107	M91802006	...	P11	...	F 133
M90001060	...	P13	...	G 130	M90825050	...	P23	...	M 121	M91058020	...	P15	...	H 113	M91802045	...	P13	...	G 105
M90101017	...	P17	...	J 150	M90853002	...	P13	...	G 128	M91059004	...	P11	...	F 103	↑	...	P15	...	H 102
M90204060	...	P7	...	D 142	M90859004	...	P3	...	B 129	M91066004	...	P31	...	R 122	M91803022	...	P3	...	B 136
M90307053	...	P23	...	M 108	↑	...	P23	...	M 137	M91071004	...	P3	...	B 102	M91910080	...	P3	...	B 105
↑	...	P25	...	N 109	M90875045	...	P25	...	N 110	↑	...	P19	...	K 139	M92075045	...	P21	...	L 103
M90316050	...	P19	...	K 107	M90883080	...	P3	...	B 108	↑	...	P21	...	L 117	↑	...	P23	...	M 116
M90317050	...	P19	...	K 110	M90901002	...	P7	...	D 143	M91073004	...	P23	...	M 141	M93001050	...	P11	...	F 106
↑	...	P23	...	M 109	M90906003	...	P3	...	B 128	M91079004	...	P3	...	B 122	M93003021	...	P19	...	K 113
↑	...	P25	...	N 108	↑	...	P17	...	J 124	M91101017	...	P17	...	J 135	M93004021	...	P19	...	K 114
M90325065	...	P15	...	H 128	M90909003	...	P3	...	B 125	M91101046	...	P7	...	D 140	M93006050	...	P13	...	G 132
M90327060	...	P23	...	M 118	↑	...	P15	...	H 115	M91102045	...	P17	...	J 164	M93020021	...	P23	...	M 107
M90330065	...	P11	...	F 105	M90920002	...	P7	...	D 109	M91104045	...	P17	...	J 148	M93202047	...	P15	...	H 131
M90352037	...	P9	...	E 108	M90922002	...	P15	...	H 139	M91108001	...	P17	...	J 163	M93220035	...	P15	...	H 130
M90406064	...	P11	...	F 142	M90939002	...	P7	...	D 110	M91109045	...	P17	...	J 158	M94001017	...	P3	...	B 132
M90421050	...	P3	...	B 131	M90971004	...	P19	...	K 126	M91110002	...	P3	...	B 123	↑	...	P19	...	K 134
↑	...	P11	...	F 102	↑	...	P21	...	L 138	M91112002	...	P17	...	J 109	↑	...	P21	...	L 111
↑	...	P31	...	R 123	M90990002	...	P5	...	C 101	M91119002	...	P11	...	F 144	M94002017	...	P23	...	M 131
M90422050	...	P5	...	C 105	↑	...	P9	...	E 101	M91127015	...	P17	...	J 101	M94003017	...	P19	...	K 101
↑	...	P17	...	J 108	↑	...	P11	...	F 137	M91129015	...	P17	...	J 127	M94003099	...	P21	...	L 136
↑	...	P21	...	L 112	↑	...	P17	...	J 117	M91131002	...	P15	...	H 146	↑	...	P27	...	P 116
M90423060	...	P15	...	H 145	M91003053	...	P31	...	R 117	M91182080	...	P3	...	B 106	M94004017	...	P23	...	M 110
M90424053	...	P17	...	J 107	M91004067	...	P7	...	D 119	M91203002	...	P13	...	G 101	M94005017	...	P19	...	K 116
M90439037	...	P29	...	Q 106	M91005067	...	P7	...	D 121	M91214015	...	P17	...	J 130	M94008017	...	P23	...	M 149
M90447037	...	P3	...	B 118	M91007045	...	P17	...	J 106	M91219015	...	P15	...	H 147	M94008070	...	P23	...	M 127
M90500085	...	P13	...	G 116	↑	...	P23	...	M 102	M91221001	...	P11	...	F 125	M94009017	...	P19	...	K 118
M90504053	...	P17	...	J 161	M91010089	...	P33	...	S 126	↑	...	P13	...	G 110	M94013017	...	P31	...	R 101
M90511050	...	P5	...	C 108	M91011004	...	P5	...	C 106	M91223001	...	P11	...	F 122	M94015021	...	P23	...	M 101
↑	...	P9	...	E 121	↑	...	P7	...	D 135	↑	...	P13	...	G 104	M94016017	...	P23	...	M 115
↑	...	P17	...	J 160	M91012050	...	P31	...	R 119	M91224001	...	P17	...	J 128	M94016021	...	P23	...	M 128
↑	...	P19	...	K 136	M91013004	...	P7	...	D 104	M91276004	...	P7	...	D 102	M95001017	...	P19	...	K 137
↑	...	P21	...	L 115	M91016022	...	P31	...	R 118	↑	...	P29	...	Q 126	↑	...	P21	...	L 116
↑	...	P23	...	M 148	M91035089	...	P29	...	Q 123	M91300004	...	P3	...	B 112	↑	...	P23	...	M 105
↑	...	P29	...	Q 120	M91050020	...	P23	...	M 125	M91304080	...	P3	...	B 109	M95001021	...	P13	...	G 125
M90512050	...	P23	...	M 133	M91053020	...	P7	...	D 133	M91382045	...	P17	...	J 112	M95002017	...	P5	...	C 111
M90512065	...	P23	...	M 117	↑	...	P11	...	F 120	M91503001	...	P13	...	G 112	↑	...	P9	...	E 119
M90513065	...	P17	...	J 133	↑	...	P23	...	M 135	M91504031	...	P15	...	H 144	↑	...	P21	...	L 106
M90516065	...	P21	...	L 114	M91054004	...	P3	...	B 103	M91506001	...	P15	...	H 136	M95003017	...	P15	...	H 150
M90601064	...	P7	...	D 123	↑	...	P7	...	D 131	M91511056	...	P5	...	C 107	↑	...	P29	...	Q 119
M90604065	...	P19	...	K 129	↑	...	P17	...	J 116	↑	...	P9	...	E 122	M95003021	...	P17	...	J 144
M90605010	...	P17	...	J 119	↑	...	P19	...	K 128	M91520002	...	P11	...	F 112	M95004017	...	P21	...	L 126
M90611060	...	P23	...	M 140	↑	...	P21	...	L 133	M91551015	...	P15	...	H 125	↑	...	P23	...	M 134
M90624053	...	P21	...	L 109	↑	...	P25	...	N 101	M91572045	...	P15	...	H 122	M95004020	...	P7	...	D 152
↑	...	P31	...	R 114	↑	...	P27	...	P 105	M91576045	...	P17	...	J 142	↑	...	P15	...	H 157
M90631050	...	P15	...	H 123	↑	...	P29	...	Q 111	↑	...	P31	...	R 132	M95004021	...	P13	...	G 107
↑	...	P31	...	R 115	↑	...	P31	...	R 128	M91602001	...	P11	...	F 118	↑	...	P17	...	J 149
M90632050	...	P15	...	H 133	M91055020	...	P7	...	D 112	M91602046	...	P7	...	D 124	M95005017	...	P3	...	B 115
M90712050	...	P31	...	R 130	M91056004	...	P15	...	H 104	M91603003	...	P15	...	H 121	↑	...	P17	...	J 113
M90802003	...	P13	...	G 131	↑	...	P17	...	J 139	M91606001	...	P11	...	F 134	↑	...	P23	...	M 147
↑	...	P25	...	N 113	↑	...	P23	...	M 143	↑	...	P15	...	H 129	M95006017	...	P15	...	H 153
M90803053	...	P21	...	L 104	↑	...	P25	...	N 102	M91610046	...	P7	...	D 150	M95006020	...	P11	...	F 138
M90806002	...	P3	...	B 120	↑	...	P31	...	R 131	M91652020	...	P17	...	J 143	M95006021	...	P19	...	K 138
M90814004	...	P19	...	K 109	M91057004	...	P29	...	Q 101	M91688015	...	P15	...	H 109	M95010017	...	P31	...	R 109

索引
INDEX-2

部品コード Parts No.	ページ Page	Fig No.	部品コード Parts No.	ページ Page	Fig No.	部品コード Parts No.	ページ Page	Fig No.	部品コード Parts No.	ページ Page	Fig No.								
M95011021	...	P21	...	L 122	MA21P0454	...	P19	...	K 131	MA46A0477	...	P19	...	K 106	MB45A1849	...	P3	...	B 113
M95013021	...	P19	...	K 124	MA22A0957	...	P23	...	M 130	MA46A0781	...	P21	...	L 110	MB45A1920	...	P23	...	M 104
M95015021	...	P17	...	J 162	MA30A0352	...	P33	...	S 107	MA46A0957	...	P19	...	K 111	MB45A1957	...	P23	...	M 126
M95045095	...	P19	...	K 148	MA30A0571	...	P33	...	S 127	MA46A0971	...	P19	...	K 104	MB45A2339	...	P31	...	R 104
M95046095	...	P21	...	L 101	MA35A0180	...	P35	...	T 118	MA46A0972	...	P19	...	K 105	MB45A2359	...	P9	...	E 105
M95049021	...	P17	...	J 138	MA35A0256	...	P35	...	T 109	MA46A1272	...	P35	...	T 116	MB45A2426	...	P9	...	E 125
M96001001	...	P19	...	K 144	MA35A0601	...	P5	...	C 104	MA46A2781	...	P21	...	L 140	MB45A2476	...	P19	...	K 133
↑	...	P21	...	L 128	MA35A1256	...	P35	...	T 110	MA46E0105	...	P23	...	M 901	MB45A2601	...	P21	...	L 134
M96001031	...	P19	...	K 115	MA35A2572	...	P11	...	F 140	MA46E1105	...	P35	...	T 117	MB45A3339	...	P31	...	R 102
M96002001	...	P19	...	K 147	MA35A6758	...	P19	...	K 135	MA61A0105	...	P23	...	M 145	MB45A3426	...	P9	...	E 126
↑	...	P21	...	L 130	MA35B7601	...	P31	...	R 111	MA61A0272	...	P23	...	M 146	MB45A4601	...	P29	...	Q 108
M96002017	...	P23	...	M 111	MA45A0196	...	P23	...	M 150	MA61A0273	...	P23	...	M 132	MB45A6601	...	P31	...	R 116
M96002020	...	P13	...	G 114	MA45A0266	...	P23	...	M 123	MA61A0361	...	P5	...	C 115	MB45B0339	...	P9	...	E 112
M96004017	...	P19	...	K 149	MA45A0273	...	P23	...	M 132	MA61A0455	...	P23	...	M 103	MB45B1339	...	P9	...	E 111
↑	...	P21	...	L 102	MA45A0308	...	P23	...	M 122	MA61A0473	...	P5	...	C 102	MB45B1359	...	P9	...	E 103
M96004052	...	P17	...	J 126	MA45A0339	...	P3	...	B 107	MA61A0474	...	P5	...	C 103	MB45B1426	...	P5	...	C 112
M96009021	...	P31	...	R 113	MA45A0359	...	P9	...	E 107	MA61A0477	...	P19	...	K 122	MB45B2359	...	P9	...	E 102
M96061021	...	P21	...	L 108	MA45A0361	...	P5	...	C 115	MA61A0797	...	P33	...	S 129	MB45B2426	...	P9	...	E 118
↑	...	P31	...	R 129	MA45A0390	...	P19	...	K 145	MA61A1272	...	P35	...	T 116	MB45B3426	...	P9	...	E 123
M96062021	...	P17	...	J 156	MA45A0434	...	P23	...	M 113	MA61A1361	...	P5	...	C 110	MB45E0150	...	P31	...	R 103
M97318099	...	P29	...	Q 116	MA45A0455	...	P23	...	M 103	MA61A2361	...	P9	...	E 124	MB45E0599	...	P29	...	Q 901
M97319099	...	P29	...	Q 114	MA45A0473	...	P5	...	C 102	MA61A2920	...	P19	...	K 123	MB45E0972	...	P31	...	R 120
M97320099	...	P29	...	Q 115	MA45A0474	...	P5	...	C 103	MA61A3359	...	P9	...	E 110	MB45E0975	...	P17	...	J 136
M97321099	...	P29	...	Q 112	MA45A0477	...	P19	...	K 102	MA61A3361	...	P9	...	E 120	MB45E1148	...	P27	...	P 119
M98003015	...	P13	...	G 108	MA45A0571	...	P19	...	K 146	MA61A4339	...	P9	...	E 113	MB45E2148	...	P27	...	P 131
M98004017	...	P23	...	M 120	MA45A0621	...	P23	...	M 119	MA61A5339	...	P9	...	E 115	MB60A0366	...	P29	...	Q 102
M99006063	...	P7	...	D 114	MA45A0751	...	P21	...	L 105	MA61A6359	...	P9	...	E 106	MB60A0601	...	P3	...	B 124
↑	...	P15	...	H 114	MA45A0776	...	P3	...	B 111	MA61E0105	...	P23	...	M 901	MB60A0694	...	P11	...	F 111
MA04A1530	...	P7	...	D 108	MA45A0778	...	P19	...	K 140	MA61E1105	...	P35	...	T 117	MB60A0740	...	P13	...	G 102
MA04A2530	...	P7	...	D 111	MA45A0797	...	P33	...	S 129	MB02A0608	...	P33	...	S 118	MB60A0750	...	P3	...	B 134
MA10A0120	...	P13	...	G 123	MA45A0921	...	P21	...	L 131	MB02A1608	...	P33	...	S 117	MB60A0915	...	P25	...	N 105
MA10A0123	...	P13	...	G 121	MA45A1361	...	P5	...	C 110	MB45A0139	...	P31	...	R 106	MB60A1601	...	P7	...	D 118
↑	...	P33	...	S 102	MA45A1390	...	P21	...	L 107	MB45A0150	...	P31	...	R 121	MB60A1780	...	P27	...	P 130
MA10B2476	...	P17	...	J 122	MA45A1601	...	P23	...	M 106	MB45A0339	...	P9	...	E 116	MB60A1990	...	P33	...	S 108
MA16A0495	...	P29	...	Q 125	MA45A1781	...	P21	...	L 113	MB45A0364	...	P21	...	L 141	MB60A2352	...	P29	...	Q 103
MA16E0210	...	P7	...	D 904	MA45A1921	...	P21	...	L 132	MB45A0390	...	P21	...	L 142	MB60A2406	...	P11	...	F 101
MA20A0194	...	P7	...	D 116	MA45A2196	...	P23	...	M 142	MB45A0407	...	P19	...	K 121	MB60A3957	...	P31	...	R 124
MA20A0361	...	P5	...	C 113	MA45A2361	...	P9	...	E 124	MB45A0426	...	P5	...	C 116	MB60A5780	...	P29	...	Q 109
MA20A0392	...	P17	...	J 131	MA45A2390	...	P21	...	L 125	MB45A0472	...	P17	...	J 118	MB60A6780	...	P29	...	Q 110
MA20A0476	...	P7	...	D 105	MA45A2426	...	P5	...	C 109	MB45A0476	...	P9	...	E 109	MB60E0234	...	P11	...	F 904
MA20A0584	...	P7	...	D 132	MA45A2601	...	P23	...	M 112	MB45A0477	...	P19	...	K 122	MB60E0682	...	P11	...	F 113
MA20A0603	...	P17	...	J 111	MA45A3339	...	P3	...	B 114	MB45A0523	...	P19	...	K 141	MB60E1682	...	P11	...	F 901
MA20A0719	...	P31	...	R 125	MA45A3359	...	P9	...	E 110	MB45A0601	...	P19	...	K 119	MB60E1956	...	P13	...	G 901
MA20A0734	...	P33	...	S 125	MA45A3361	...	P9	...	E 120	MB45A0603	...	P31	...	R 112	MB60E2750	...	P7	...	D 113
MA20A0740	...	P13	...	G 118	MA45A3601	...	P23	...	M 151	MB45A0767	...	P19	...	K 143	MB60E3339	...	P25	...	N 902
MA20A0777	...	P3	...	B 110	MA45A3920	...	P19	...	K 123	↑	...	P21	...	L 127	MB60E6339	...	P3	...	B 127
MA20A0980	...	P25	...	N 119	MA45A4339	...	P9	...	E 113	MB45A0776	...	P31	...	R 110	MB61A0436	...	P25	...	N 114
MA20A1780	...	P27	...	P 106	MA45A5339	...	P9	...	E 115	MB45A0849	...	P3	...	B 101	MB61A0963	...	P29	...	Q 117
MA20A1910	...	P17	...	J 134	MA45A5758	...	P21	...	L 124	MB45A0957	...	P19	...	K 117	MB61A3454	...	P23	...	M 124
MA20A5920	...	P19	...	K 112	MA45A6359	...	P9	...	E 106	MB45A1339	...	P9	...	E 117	MB62A0352	...	P7	...	D 103
MA20A6571	...	P29	...	Q 124	MA45A7426	...	P23	...	M 144	MB45A1359	...	P9	...	E 104	MB62A0453	...	P13	...	G 113
MA20A8571	...	P29	...	Q 118	MA45E0431	...	P19	...	K 103	MB45A1426	...	P5	...	C 114	MB62A0454	...	P17	...	J 129
MA20A9571	...	P23	...	M 114	MA46A0105	...	P23	...	M 145	MB45A1476	...	P9	...	E 114	MB62A0456	...	P19	...	K 142
MA20E0450	...	P13	...	G 119	MA46A0272	...	P23	...	M 146	MB45A1601	...	P19	...	K 120	MB62A0626	...	P15	...	H 140
MA20E3688	...	P27	...	P 125	MA46A0359	...	P19	...	K 108	MB45A1780	...	P27	...	P 129	MB62A0767	...	P19	...	K 132

索引
INDEX-3

部品コード Parts No.	ページ Page	Fig No.	部品コード Parts No.	ページ Page	Fig No.	部品コード Parts No.	ページ Page	Fig No.	部品コード Parts No.	ページ Page	Fig No.								
MB62A0767	...	P21	...	L 120	ME45A0484	...	P21	...	L 137	MF70A0350	...	P15	...	H 143	MS01A2392	...	P17	...	J 157
MB62A1599	...	P29	...	Q 121	ME45A0508	...	P25	...	N 103	MF70A0352	...	P11	...	F 117	MS01A2572	...	P17	...	J 153
MB62A2599	...	P29	...	Q 122	ME45A0523	...	P21	...	L 123	MF70A1180	...	P7	...	D 153	MS01A3352	...	P17	...	J 901
MB62A4601	...	P3	...	B 130	ME45A0571	...	P21	...	L 129	MF80A0780	...	P27	...	P 114	MS01A4454	...	P17	...	J 155
MB62E0780	...	P27	...	P 124	ME45A0600	...	P7	...	D 101	MF90A0361	...	P17	...	J 104	MS01A8796	...	P27	...	P 109
MB69A0339	...	P9	...	E 116	ME45A0601	...	P29	...	Q 107	MF90A0976	...	P33	...	S 112	MS01A9796	...	P27	...	P 132
MB69A0359	...	P9	...	E 105	ME45A0738	...	P15	...	H 148	MG30A0664	...	P11	...	F 128	MS01E0351	...	P17	...	J 147
MB69A0407	...	P19	...	K 121	ME45A0770	...	P31	...	R 126	MG30A0740	...	P15	...	H 117	MS01E0430	...	P17	...	J 137
MB69A0426	...	P9	...	E 125	ME45A1484	...	P19	...	K 127	MG30A0760	...	P15	...	H 901	MS01E0580	...	P11	...	F 902
MB69A0523	...	P19	...	K 141	ME45A1601	...	P31	...	R 108	MG30A0833	...	P15	...	H 120	MS01E0975	...	P17	...	J 151
MB69A1339	...	P9	...	E 117	ME45E0270	...	P25	...	N 901	MG30B0226	...	P15	...	H 108	MS02A0128	...	P11	...	F 130
MB69A1426	...	P9	...	E 126	ME45E0519	...	P17	...	J 114	MG30B0740	...	P15	...	H 127	↑	...	P33	...	S 101
MB69A1920	...	P23	...	M 104	ME45E0688	...	P27	...	P 110	MG43A0181	...	P7	...	D 141	MS02A0463	...	P15	...	H 902
MB69B0339	...	P9	...	E 112	ME45E0691	...	P33	...	S 902	MG50A0740	...	P11	...	F 114	MS02A0479	...	P33	...	S 121
MB69B0359	...	P9	...	E 102	ME45E0746	...	P17	...	J 115	MG75A0265	...	P15	...	H 135	MS02A0976	...	P33	...	S 115
MB69B0426	...	P9	...	E 118	ME45E1519	...	P17	...	J 141	MG75A1476	...	P7	...	D 130	MS02A1477	...	P25	...	N 115
MB69B1339	...	P9	...	E 111	ME45E1688	...	P27	...	P 111	MM10A1479	...	P33	...	S 122	MS02A1976	...	P33	...	S 114
MB69B1426	...	P9	...	E 123	ME45E2519	...	P25	...	N 107	MM11A0245	...	P7	...	D 126	MS02A2456	...	P19	...	K 130
MB69E0150	...	P31	...	R 103	ME45E2688	...	P27	...	P 118	MM11A0352	...	P13	...	G 111	↑	...	P21	...	L 119
ME03A0270	...	P25	...	N 106	ME45E3688	...	P27	...	P 120	MM11A0556	...	P7	...	D 147	MS02A2976	...	P33	...	S 113
ME10A0148	...	P13	...	G 117	ME45E4688	...	P27	...	P 122	MM11A0702	...	P7	...	D 125	MS02A4729	...	P25	...	N 111
ME10A0261	...	P15	...	H 103	ME69A0359	...	P9	...	E 104	MN10A0135	...	P27	...	P 108	MS02B0257	...	P23	...	M 138
ME10A0408	...	P19	...	K 125	ME69B0359	...	P9	...	E 103	MN10A1456	...	P11	...	F 104	MS02E0460	...	P15	...	H 119
ME10A0572	...	P15	...	H 105	ME69E0691	...	P33	...	S 902	MN10A3245	...	P35	...	T 113	MS02E0983	...	P25	...	N 112
ME10A0742	...	P3	...	B 104	MF00A0181	...	P7	...	D 136	MN52A1245	...	P7	...	D 148	MS03A0101	...	P35	...	T 101
ME10A0763	...	P15	...	H 111	MF00A0553	...	P7	...	D 137	↑	...	P33	...	S 105	MS03A0181	...	P35	...	T 114
ME10A0956	...	P15	...	H 124	MF00A0608	...	P33	...	S 119	MN60A0620	...	P27	...	P 117	MS03A0256	...	P35	...	T 107
ME10A1252	...	P15	...	H 142	MF00A2780	...	P27	...	P 107	MN60A0750	...	P17	...	J 110	MS03A0262	...	P15	...	H 138
ME10A1780	...	P27	...	P 101	MF00E0550	...	P7	...	D 903	MN70A1780	...	P15	...	H 116	MS03A0417	...	P7	...	D 117
ME10A1956	...	P15	...	H 118	MF01A0181	...	P11	...	F 132	MN72A1694	...	P11	...	F 109	↑	...	P33	...	S 103
ME10A6910	...	P15	...	H 110	MF01A0259	...	P11	...	F 107	MS01A0121	...	P13	...	G 127	MS03A0703	...	P15	...	H 132
ME10A7910	...	P15	...	H 112	MF01A0476	...	P11	...	F 110	MS01A0160	...	P3	...	B 116	MS03A1101	...	P17	...	J 120
ME10E0452	...	P13	...	G 902	MF01A0565	...	P33	...	S 104	MS01A0192	...	P17	...	J 132	MS03A1256	...	P35	...	T 108
ME10E1830	...	P3	...	B 119	MF01A1476	...	P11	...	F 108	MS01A0329	...	P13	...	G 129	MS03A1530	...	P25	...	N 117
ME10E3601	...	P25	...	N 104	MF10A0149	...	P33	...	S 120	MS01A0348	...	P17	...	J 145	MS03A1572	...	P15	...	H 134
ME20A1780	...	P27	...	P 123	MF10A0181	...	P7	...	D 151	MS01A0350	...	P11	...	F 124	MS03A2101	...	P35	...	T 102
ME20E0990	...	P33	...	S 901	MF10A0187	...	P7	...	D 146	MS01A0361	...	P3	...	B 126	MS03A2780	...	P27	...	P 113
ME25A0434	...	P15	...	H 155	MF10A0267	...	P15	...	H 137	MS01A0383	...	P11	...	F 905	MS03A6154	...	P15	...	H 106
ME25A0454	...	P11	...	F 141	MF10A0325	...	P11	...	F 136	MS01A0477	...	P3	...	B 117	MS03B0838	...	P17	...	J 125
ME25A0477	...	P15	...	H 149	MF10A0553	...	P7	...	D 145	MS01A0508	...	P13	...	G 106	MS03E0662	...	P11	...	F 135
ME25A0551	...	P7	...	D 106	MF10A0555	...	P7	...	D 127	MS01A0572	...	P13	...	G 133	MS04E1210	...	P35	...	T 111
ME25A0571	...	P15	...	H 152	MF10A0709	...	P7	...	D 144	MS01A0611	...	P13	...	G 124	MS05A0976	...	P33	...	S 110
ME25A0601	...	P15	...	H 151	MF10A1245	...	P35	...	T 112	MS01A0660	...	P11	...	F 127	MS05A1976	...	P33	...	S 109
ME25A0682	...	P11	...	F 143	MF10A1555	...	P7	...	D 138	MS01A0663	...	P11	...	F 126	MS06A0567	...	P33	...	S 128
ME25A0833	...	P11	...	F 139	MF10A2740	...	P27	...	P 102	MS01A0740	...	P27	...	P 115	MS07A0228	...	P17	...	J 105
ME25A0950	...	P7	...	D 107	MF20A0130	...	P31	...	R 105	MS01A0761	...	P13	...	G 115	MS08A0616	...	P13	...	G 122
ME25A1454	...	P15	...	H 156	MF21D0181	...	P11	...	F 129	MS01A0833	...	P13	...	G 103	MS08A0708	...	P17	...	J 152
ME25E0190	...	P7	...	D 901	MF36A0245	...	P7	...	D 139	MS01A0891	...	P13	...	G 109	MS09A0950	...	P13	...	G 126
ME25E0331	...	P11	...	F 906	MF36A0750	...	P17	...	J 103	MS01A1392	...	P17	...	J 159	MS10A0180	...	P35	...	T 115
ME40A0454	...	P23	...	M 136	MF36A1180	...	P7	...	D 134	MS01A1476	...	P17	...	J 121	MS10A0232	...	P11	...	F 903
ME40A0571	...	P15	...	H 154	MF40E0193	...	P33	...	S 106	MS01A1572	...	P17	...	J 146	MS10A0780	...	P27	...	P 121
ME40A1508	...	P29	...	Q 113	MF60A0700	...	P15	...	H 126	MS01A1616	...	P35	...	T 103	MS10A0976	...	P33	...	S 116
ME40A5601	...	P21	...	L 135	MF60A0742	...	P27	...	P 103	MS01A1739	...	P3	...	B 121	MS10A0982	...	P25	...	N 116
ME45A0230	...	P11	...	F 121	MF60A2740	...	P11	...	F 123	MS01A1740	...	P27	...	P 112	MS10A1456	...	P3	...	B 135
ME45A0407	...	P21	...	L 139	MF60A5740	...	P27	...	P 127	MS01A1976	...	P33	...	S 111	MS10A1740	...	P11	...	F 115

索引
INDEX-4

部品コード Parts No.	ページ Page	Fig No.	部品コード Parts No.	ページ Page	Fig No.	部品コード Parts No.	ページ Page	Fig No.	部品コード Parts No.	ページ Page	Fig No.
MS10A1976	*** P33	*** S 123									
MS10A2976	*** P33	*** S 124									
MS13A0572	*** P23	*** M 139									
MS13A0758	*** P21	*** L 121									
MS13A2454	*** P21	*** L 118									
MS13A2477	*** P23	*** M 129									
MS14A0350	*** P7	*** D 120									
MS14A0553	*** P7	*** D 128									
MS14A0572	*** P7	*** D 122									
MS14A0682	*** P11	*** F 119									
MS14A0740	*** P27	*** P 128									
MS14A0838	*** P17	*** J 123									
MS14A1180	*** P7	*** D 129									
MS14A1620	*** P27	*** P 104									
↑	*** P31	*** R 127									
MS14A3601	*** P17	*** J 140									
MS14A3603	*** P17	*** J 154									
MS14A3780	*** P27	*** P 126									
MS14E0180	*** P7	*** D 902									
MS17A0125	*** P13	*** G 120									
MS17A1120	*** P35	*** T 104									
MT60A0802	*** P7	*** D 149									
MV30A0256	*** P15	*** H 141									
MV30A1256	*** P35	*** T 105									
MV35A0106	*** P35	*** T 106									
MV88A0740	*** P11	*** F 116									

 **三菱電機株式会社** 〒100-8310 東京都千代田区丸の内 2-2-3(三菱電機ビル)

お問い合わせは下記へどうぞ

F A システム事業本部 機器計画部 駆動機器グループ 〒104-6212 東京都中央区晴海 1-8-12 オフィスタワーZ14 階
代表電話番号 (03) 6221-6160 代表 F A X 番号 (03) 6221-6168

 **MITSUBISHI ELECTRIC CORPORATION**

FACTORY AUTOMATION SYSTEM

OFFICE TOWER "Z" 14F 8-12 1chome, Harumi CHUO-KU, TOKYO 104-6212, JAPAN

Phone : +81-3-6221-6060

Fax : +81-3-6221-6076